

High Accuracy Time Distribution in Telecom

Why and Where?



Typical network architecture

Distributed Grandmaster clocks

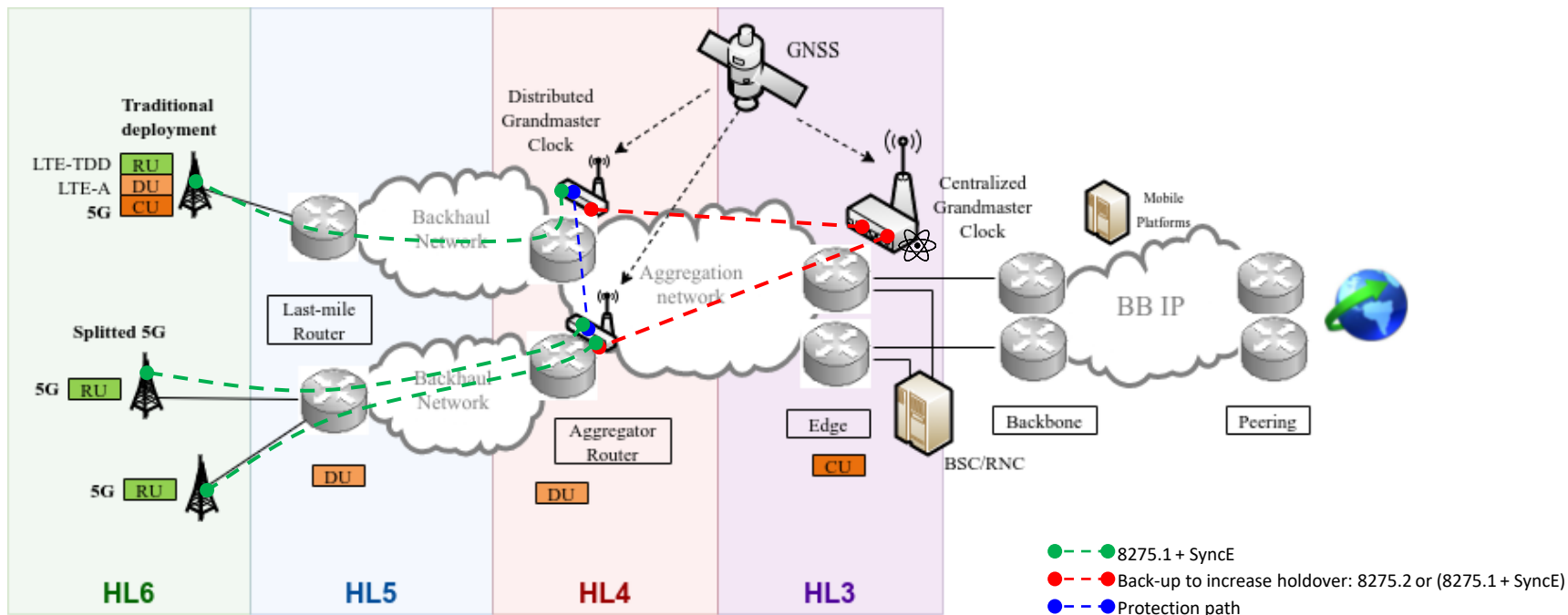

Based on I. De Francesca (Telefonica) @ ESA NAVISP thematic open calls «PNT in 5G», 21/10/2020

New 5G requirements

Allowing new applications



Tech / Application	Time-error	
RU-GMC (DU-GMC)	+/- 1.5 μ sec (+/- 1.1 μ sec)	<i>Absolute</i>
Intra-band non-contiguous CA	+/- 130 nsec	<i>Relative</i>
Inter-band CA	+/- 130 nsec	<i>Relative</i>
Coordinated Multi-Point (CoMP)	+/- 130 nsec	<i>Relative</i>
Intra-band contiguous Carrier Aggregation (CA)	+/- 65 nsec	<i>Relative</i>
MIMO / Transmit Diversity (Cat A+)	+/- 32 nsec	<i>Relative</i>
High-Accuracy Positioning Services (same DU)	10 nsec	<i>Relative</i>
Self-driving / Autonomous car	< 5 nsec	<i>Relative</i>

Relative VS Absolute

Where?

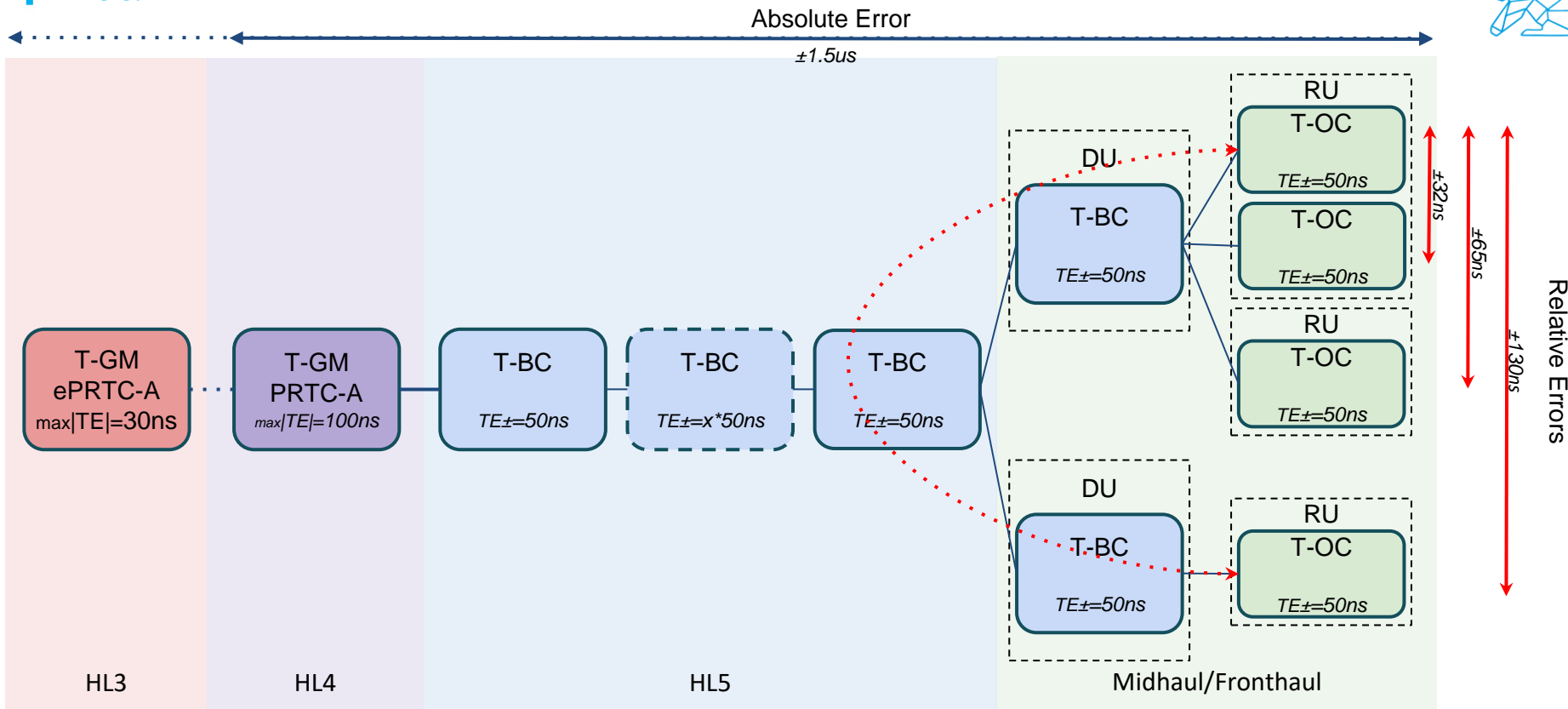

8275.1 vs HA/WR : Timing budget

Reducing timing budget at each hop allow to increase reliability

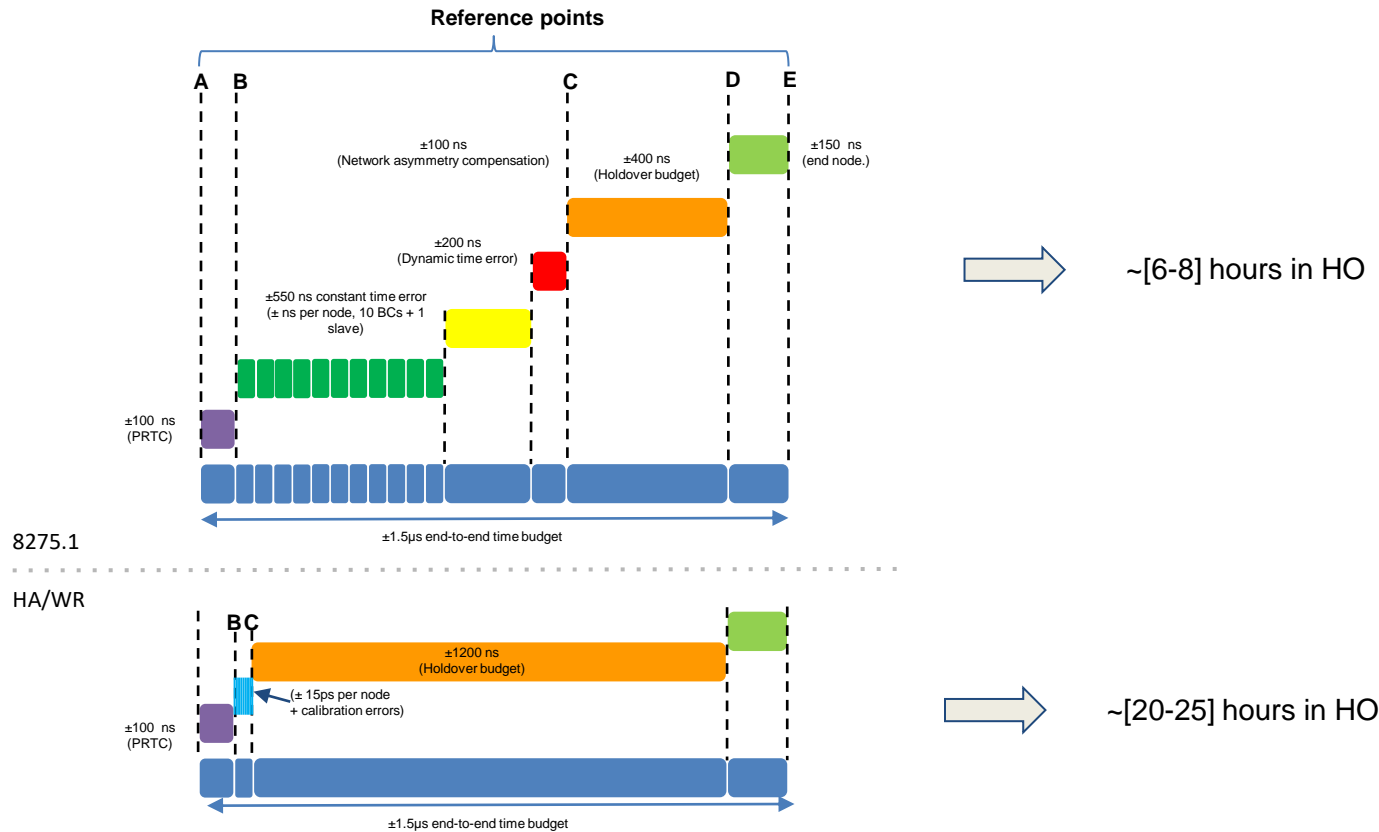

ITU-T 8275.1 vs PTP-HA (WR)

What are the key differences...



	8275.1	WR/HA
Does not need specific Hardware for each node	✗	✗
Needs L1-sync frequency synthonization	✓	✓
Independant Phase & Frequency	✓	✗
Phase-tracking	✗	✓
Precision for each hop	±16ns	±15ps
Enhanced calibration (PHY and link asymetrie)	✗	✓
Support all features of IEEE-2019	⚠	✓
Timing & 10G/40G/100G data traffic on the same network	+	✗
Compatible with many vendors	✓	⚠

Interoperability

When PTP-HA meets third party devices



WR-PTP requires a specific hardware to track the phase. How to benefit from its performance in other hardware?

- PTP-HA in upper layer fully compatible to act as a 8275.1+SyncE GM (forwarding PTP clock Quality)
- Integrating using HATI (High Accuracy Timing IP) IP-CORE into FPGA of 3rd party devices

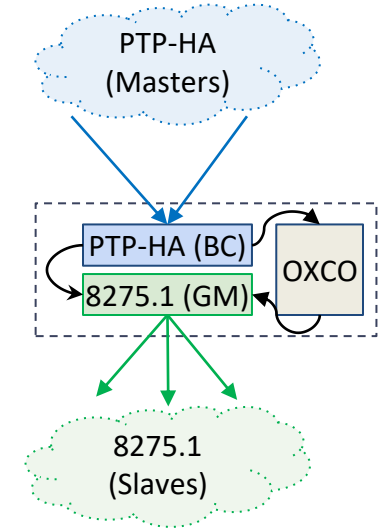
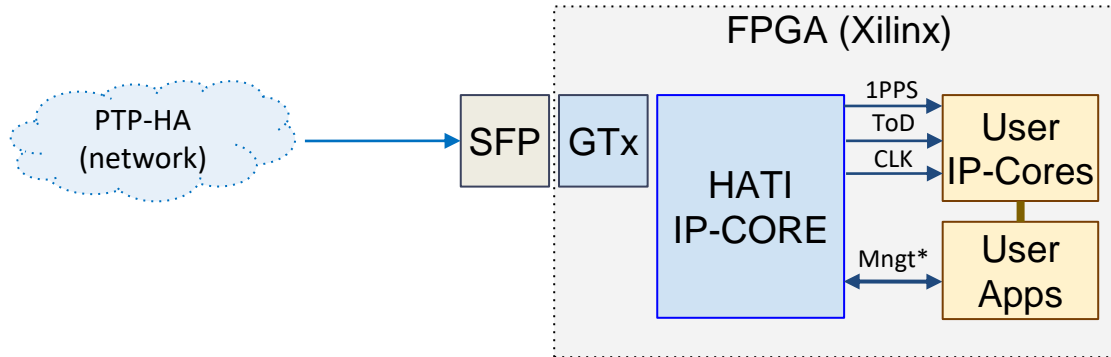

Bring ePRTC specification nears final-node

The trade-off between accuracy/reliability VS price



Using PTP-HA from ePRTC (HL3) until:

- HL5 levels (Only last hop using 8275.1)
- HL4 levels (PRTC \Rightarrow ePRTC)
- HL3 levels (linked GNSS \Rightarrow cnPRTC)



ePRTC is the best way to protect against long-lasting solar flare events

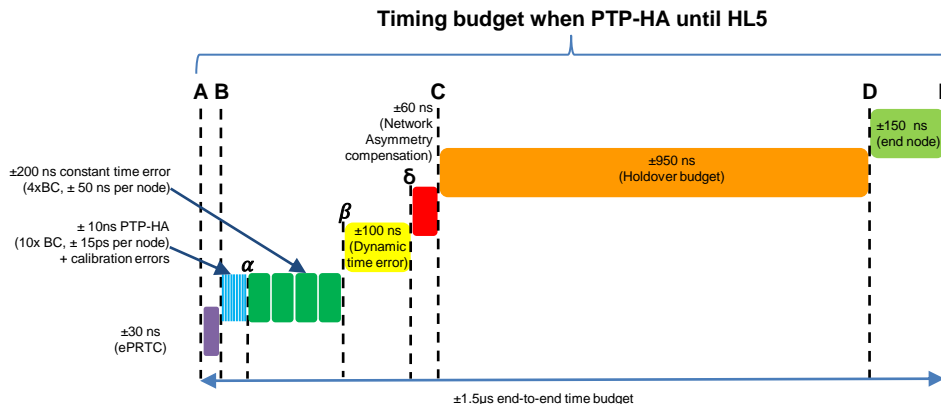

Typical network architecture (II)

Bringing ePRTC specifications near final node

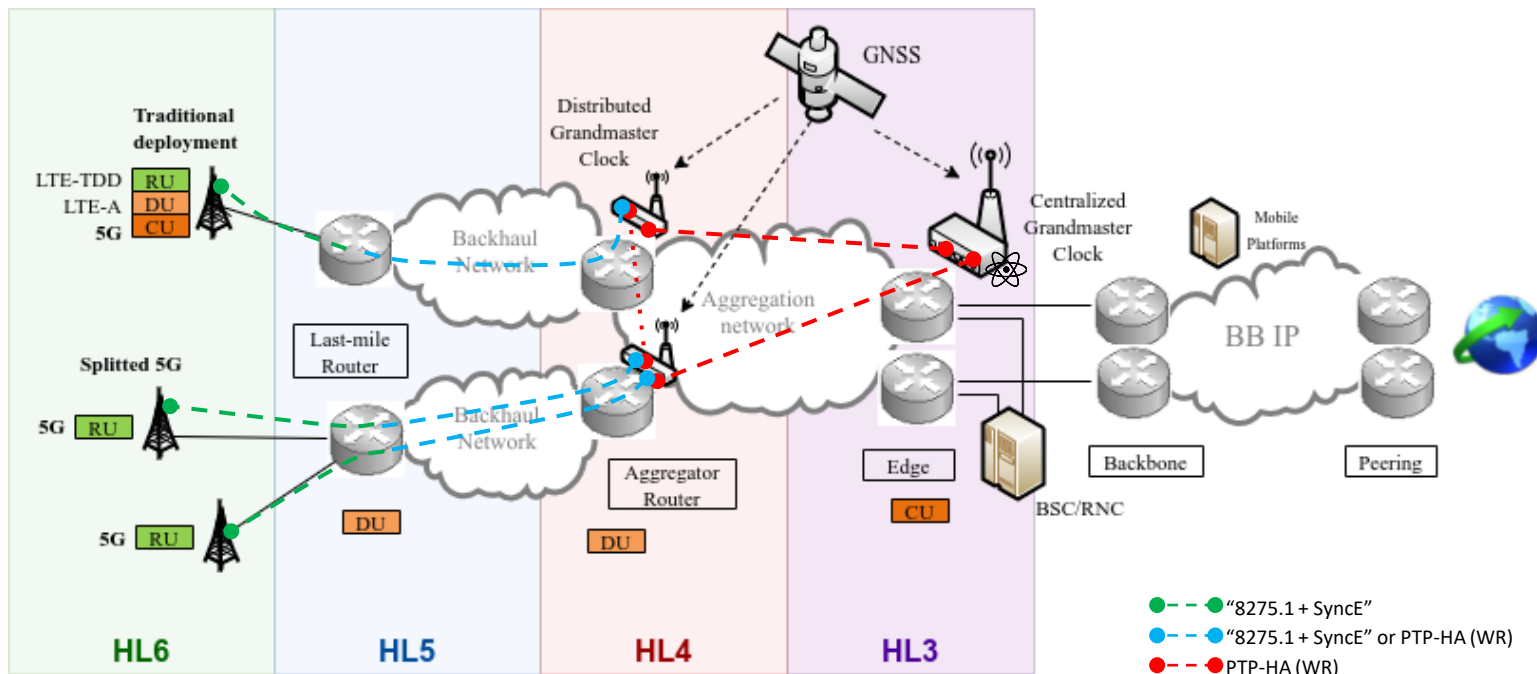

- - - ● "8275.1 + SyncE"
- - - ● "8275.1 + SyncE" or PTP-HA (WR)
- - - ● PTP-HA (WR)

Combining GNSS & PTP-HA

ROOT project: Rolling Out OSNMA for the secure synchronization of Telecom networks



To ensure failing-over the next timing source the GNSS receiver should implements best-in-class algorithms to handle a **fast** and reliable Spoofing/Jamming detection.

- Multi-band & multi-constellation
 - Ionosphere variation
- GNSS OSNMA Authentication
- Interference detection algorithms

The objective of ROOT project is to simulate spoofing/jamming attacks on a reference 5G architecture at Telefonica Labs.



<https://www.gnss-root.eu/>

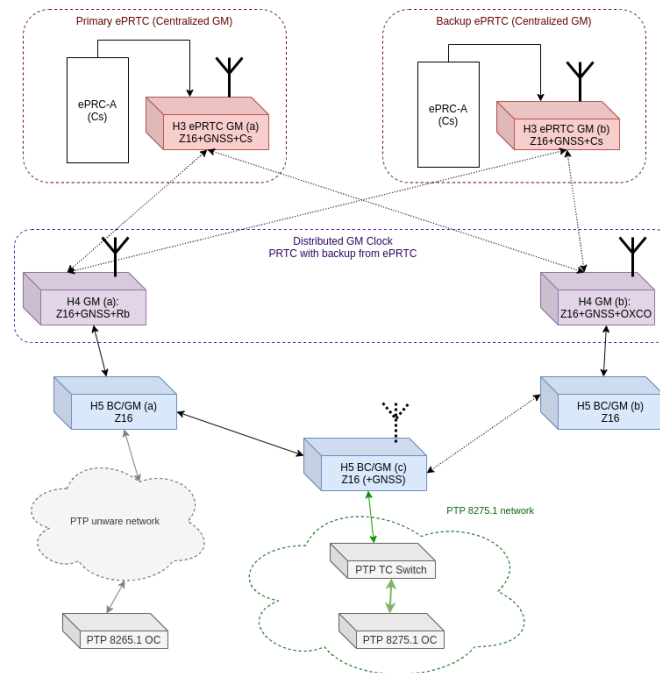

This work was developed within the ROOT project (www.gnss-root.eu) funded by the European GNSS Agency under the European Union's Horizon 2020 – G.A. n. 101004261.

Linked GNSS

Combining PTP-HA and GNSS to get the best of both worlds



- Fiber calibration correction algorithm to improve accuracy
- GNSS calibration and accuracy improved based on common view



Addressed both PTP and GNSS potential vulnerabilities

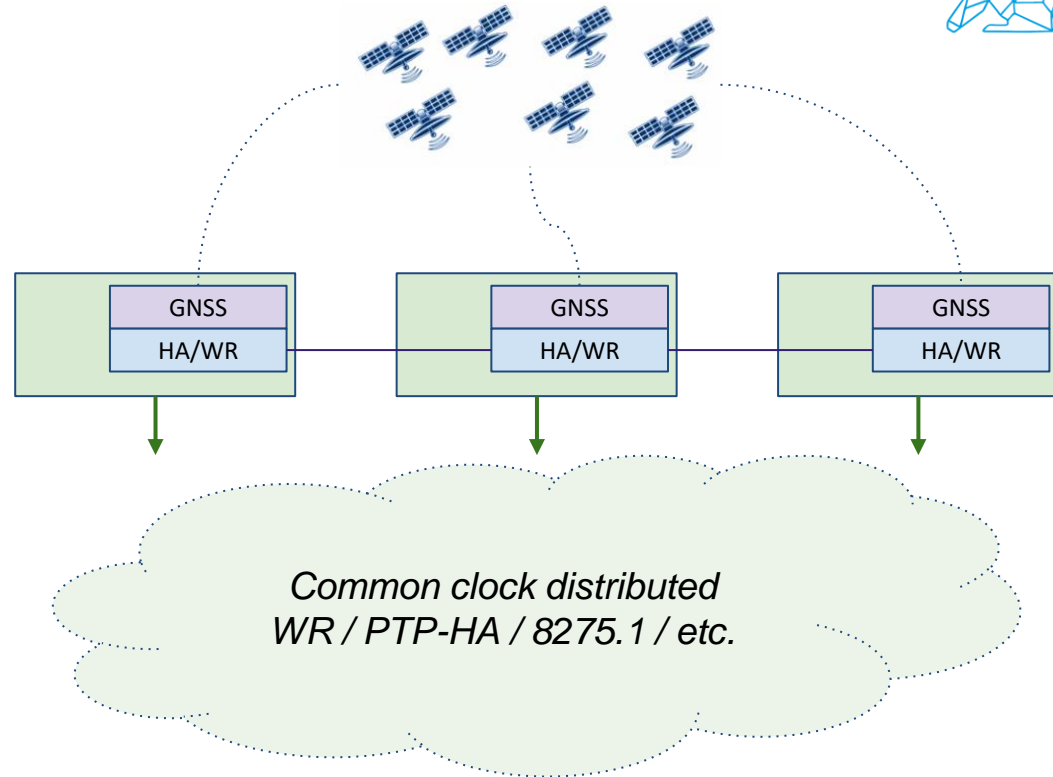

Supervision & Monitoring

Monitoring multiple PTP sources by devices synchronized through PTP-HA



- Finally PTP-HA can be used in critical places to supervise the synchronization through standard ITU-T 8275.1 as its performance are at least 10 times better than PTP+Sync-e
- Ultra Reliable Low Latency Communications (URLLC) are an emerging trend in 5G technology. Even if those does not directly needs PTP-HA performance, it seems that monitoring their performance to nanoseconds level seems appropriate.

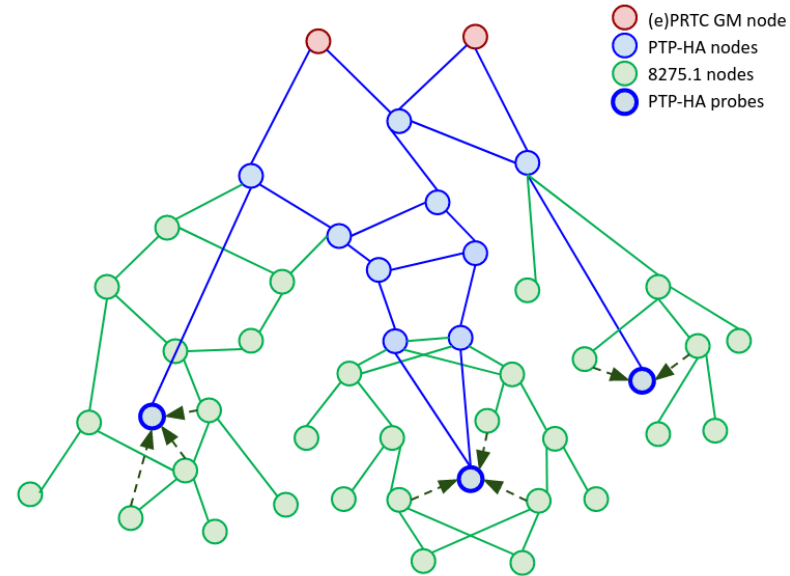

Wrap-up: Key Benefits

Sub-nanosecond accuracy through PTP-HA (WR) allow to....



Increase Holdover budget

By consuming little timing-budget at each hops, PTP-HA allows more time in holdover without compromising the total timing budget (1.5us)

Linking GNSS

The accuracy of PTP-HA allows to connect and compare GNSS receiver between them to detect abnormal behaviour

Supervising ITU-T PTP

Real-time multi-source timing comparison benefiting from the accuracy of PTP-HA. Improved traceability, resiliency and guaranteed assured PNT

Future proof solution

Targeting sub-nanosecond to distribute timing through 5G RAN allow to target future applications such as positioning

SEVEN
Solutions

Seven Solutions



www.sevensols.com

Border areas

When relative becomes absolute

