

Atomic Clock Technology

ITSF 07

13 November 2007

Dr. R. Michael Garvey

rmgarvey@symmetricom.com



- ▶ Goals and definitions of terms
- ▶ Atomic resonance properties and interrogation techniques
- ▶ Basic atomic clock architecture
- ▶ Cesium beam atomic clocks
- ▶ Hydrogen maser atomic clocks
- ▶ Rubidium gas cell atomic clocks
- ▶ Contrast cesium, hydrogen, and rubidium performance
- ▶ Other clock technologies

Goals



- ▶ Understand different clock technologies so that intelligent decisions can be made to optimize system performance, cost, lifetime and reliability.

Terms: Normalized Frequency



▶ Normalized frequency:

- Also called “fractional frequency offset”

$$y = \frac{(\nu - \nu_0)}{\nu_0}$$

- Example:

-1 Hz offset at 5 MHz (4 999 999 Hz) is $-2e-7$

- ▶ The Allan deviation is a statistical measure (analogous to the well known standard deviation) of frequency stability.

$$\sigma_y(\tau) = \left[\frac{1}{2(M-1)} \sum_{i=1}^{M-1} (\bar{y}_{i+1} - \bar{y}_i)^2 \right]^{1/2}$$

- ▶ Allan deviation can be predicted from basic atomic resonance parameters (more on this later)

Why *Atomic* Clocks?



- ▶ Atoms of a given element and isotope are identical
- ▶ Properly designed apparatus can interrogate atomic resonances to form precise and stable frequency references
- ▶ The best atoms are “hydrogen like” in their atomic structure: ^1H , ^{133}Cs , ^{87}Rb .
- ▶ While cesium defines the SI second, stored ions and optical transitions in other atoms ($^{199}\text{Hg}^+$, $^{171}\text{Yb}^+$, $^{88}\text{Sr}^+$, Ca) may be candidates for evolutionary laboratory standards.

Basic (Passive) Atomic Clock

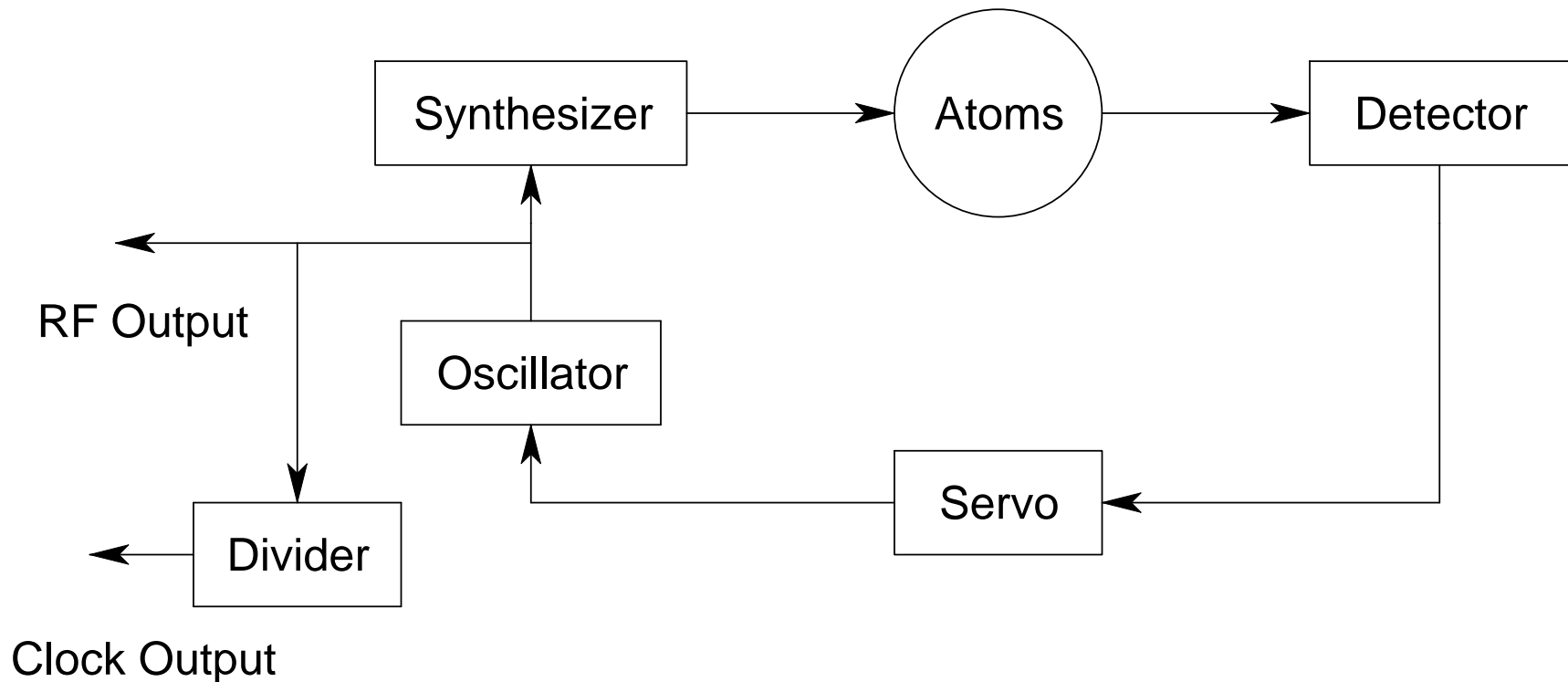

Cesium: $\nu_0 = 9\,192\,631\,770$ Hz (definition)

Hydrogen: $\nu_0 = 1\,420\,405\,751.770(3)$ Hz

Rubidium: $\nu_0 = 6\,834\,682\,610.904\,29(9)$ Hz

Atomic Energy Levels and Resonance

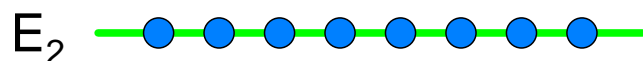

$$E_2 - E_1 = h\nu_0$$

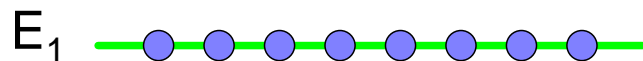

- Atoms can reside only in well defined energy states
- Transitions between energy states define a resonance, usually in the microwave region

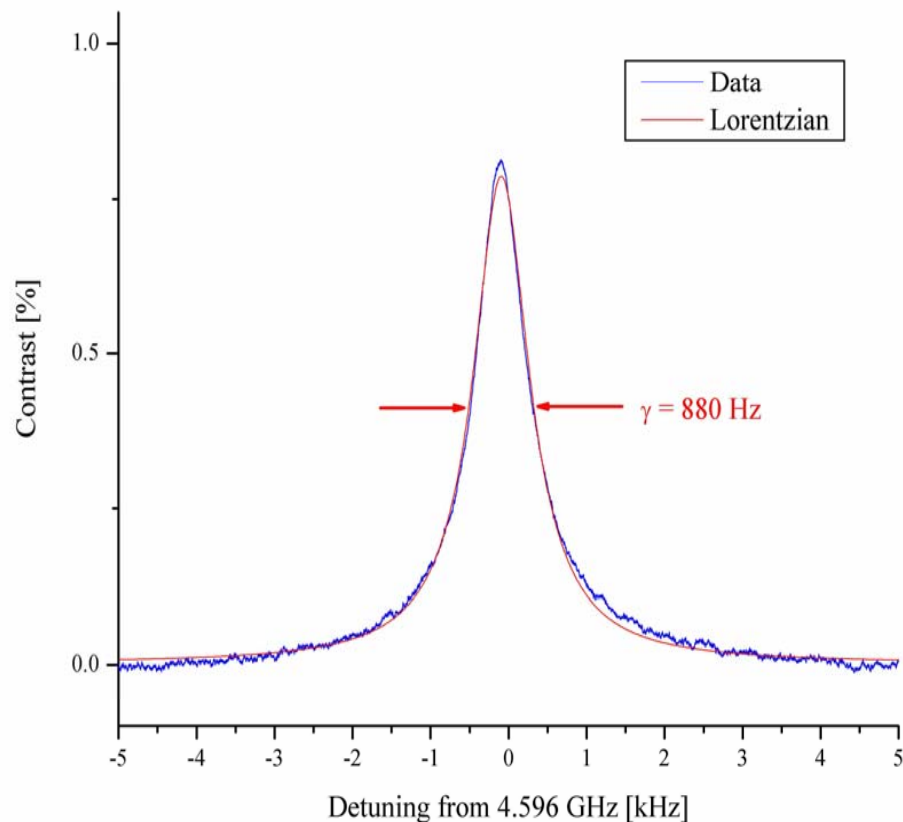

Accuracy and Stability

Accuracy vs Stability

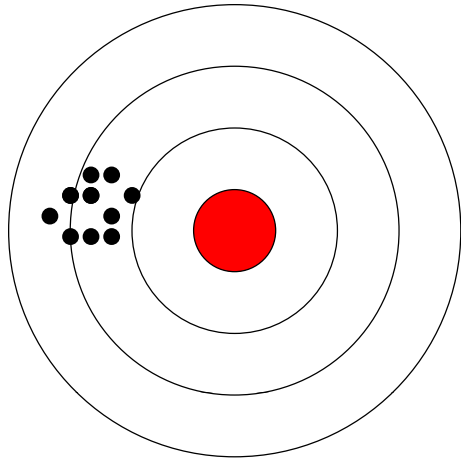

Stable-not accurate

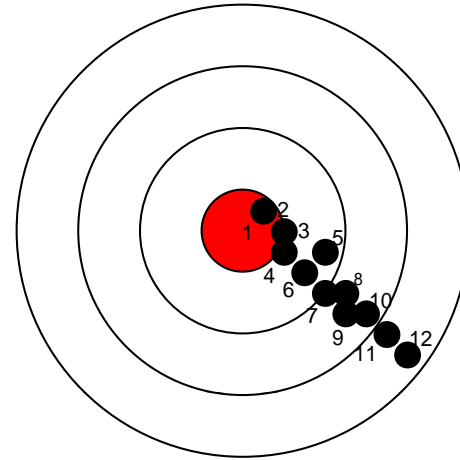

Stable-linear drift-not accurate

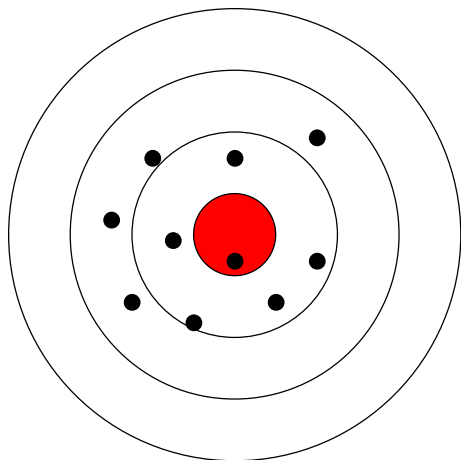

Accurate-not stable (noisy)

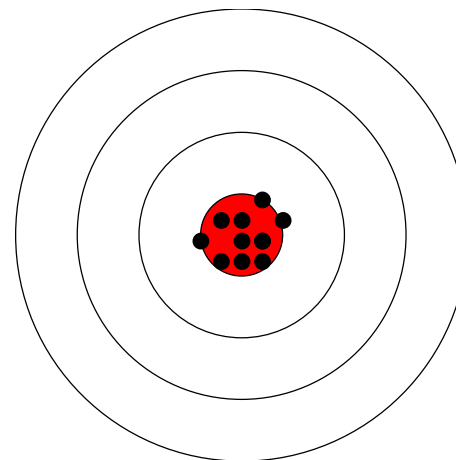

Stable and Accurate

- ▶ Accuracy: preserve the intrinsic accuracy of the atomic resonance
- ▶ Short Term Stability: extract information with highest signal-to-noise from the atoms
Characterized with Allan deviation
- ▶ Long Term Stability: control the effects of time (aging) and environment (e.g. temperature) on the atomic interrogation?
- ▶ Accuracy and stability are usually interrelated.
- ▶ How do we achieve reasonable size, cost, and operational reliability?

- ▶ Presumption of ensemble of identical unperturbed atoms at rest at 0 K
- ▶ Realities of practical devices:
 - Atoms are in motion: Doppler effects
 - Confinement effects
 - Interrogation effects
 - Environmental effects

- ▶ Calibration does not guarantee accuracy indefinitely
- ▶ The second is the duration of 9 192 631 770 periods of the radiation corresponding to the transition between the two hyperfine levels of the ground state of the cesium 133 atom
13th Conférence Général des Poids et Mesures (1967)
Clarification of 1997: ...cesium atoms at rest at a temperature of 0 K.
- ▶ Stability implies absence of noise or change—says nothing about accuracy

Frequency Offsets



- ▶ Clocks operate with frequency offsets with respect to the atomic resonance frequency; understanding and controlling these offsets is essential
- ▶ “Primary” frequency standards either have no offsets or we can precisely calculate and control offsets
- ▶ Offsets we can calculate and stabilize are OK
- ▶ Some offsets can’t be exactly calculated and require calibration

Atomic Resonance Requirements



- ▶ Narrow resonance – we seek resonances with high quality factor

$$Q = \frac{\nu_0}{W}$$

ν_0 is resonance frequency and
 W is atomic linewidth

- ▶ High signal-to-noise ratio – good short term stability

$$\sigma_y(\tau) \approx \frac{1}{S : N * Q}$$

Atomic State Populations

--Atoms can reside only in discrete energy states

--States populations are essentially equal for microwave resonances in thermal equilibrium

--Signal-to-Noise considerations require we alter the population distribution

--Common techniques to alter the population distribution include “optical pumping” and “state selection”

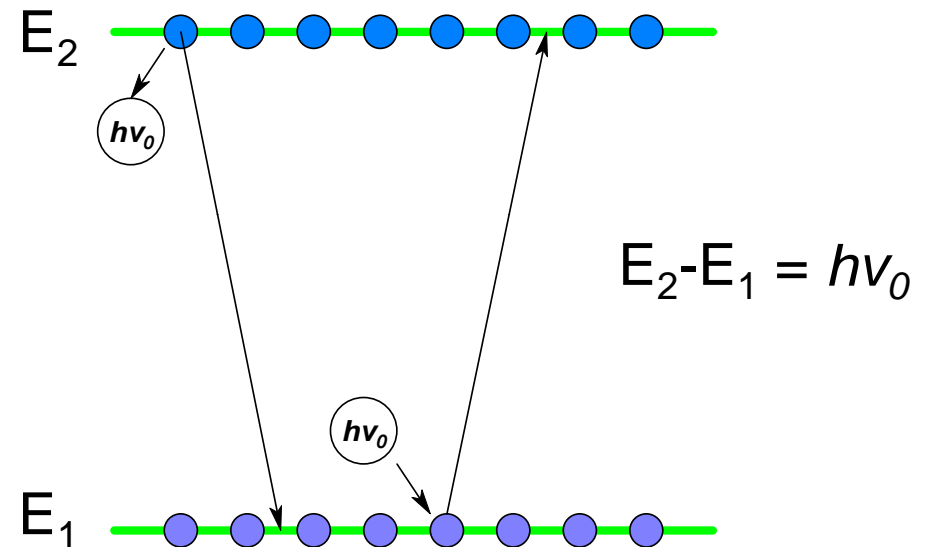

Goal: deplete one state, induce transitions back into this state, detect the results

Cesium Beam Frequency Standards

- ▶ Cesium (caesium) resonance forms the internationally acknowledged definition of the SI second interval of time
- ▶ Mature technology, excellent reliability and stability and performance at reasonable cost
 - Two levels of performance in commercial products today
- ▶ Device of choice when superior long term stability (and environmental immunity) or when autonomy is required
 - Intrinsic accuracy--calibration not required
 - No “aging” of frequency

Cesium Beam Tube Cartoon

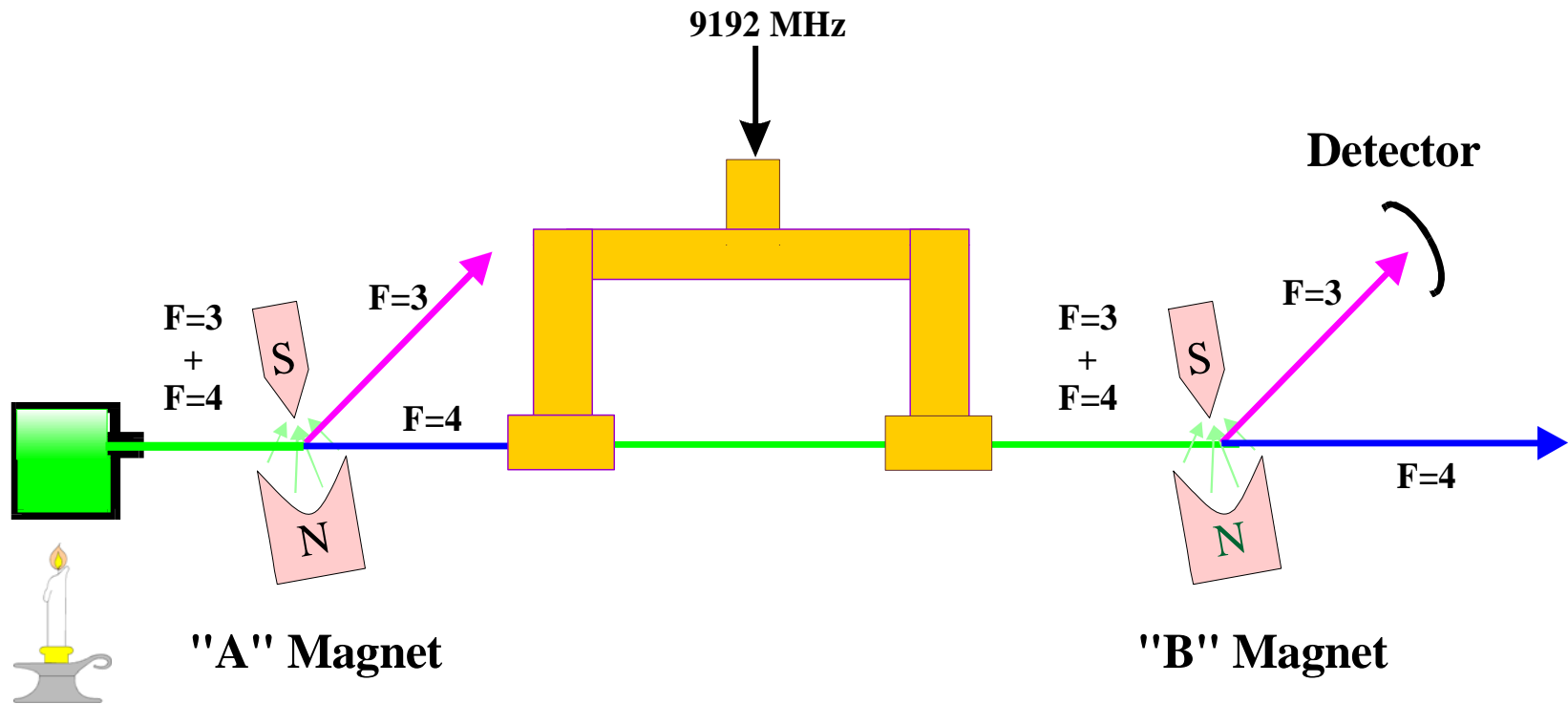

Magnetically-Selected CBT

Cesium Beam Tube



5071A Caesium Beam Tube Cut-away

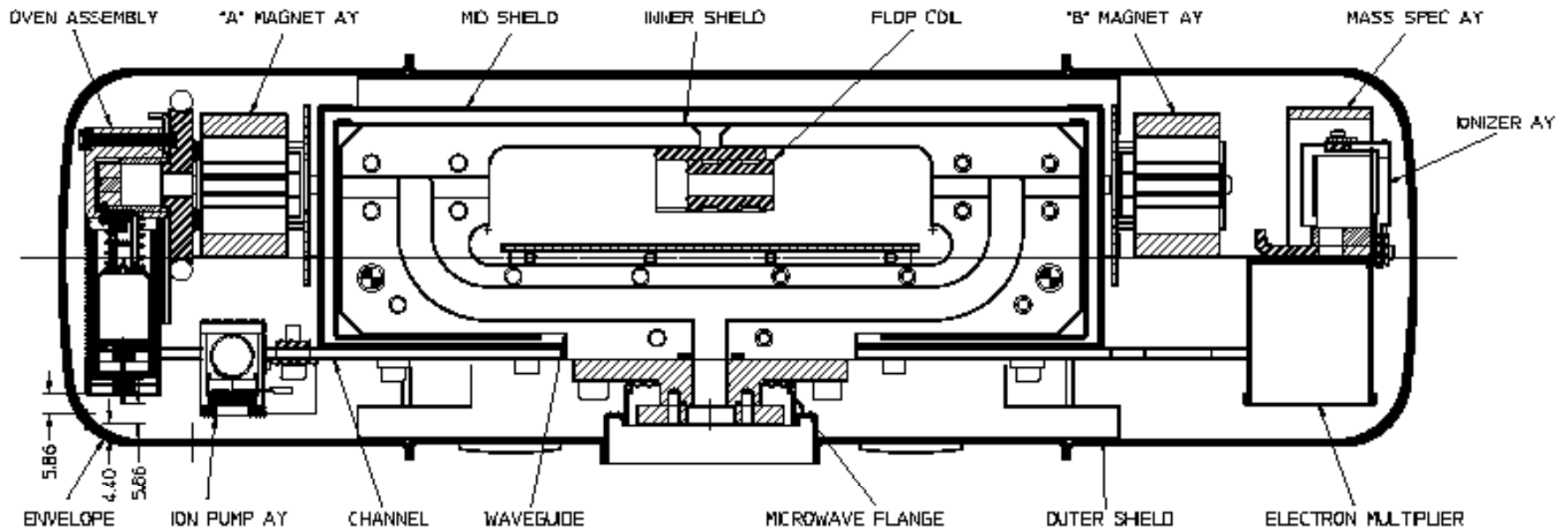

Cesium Spectrum

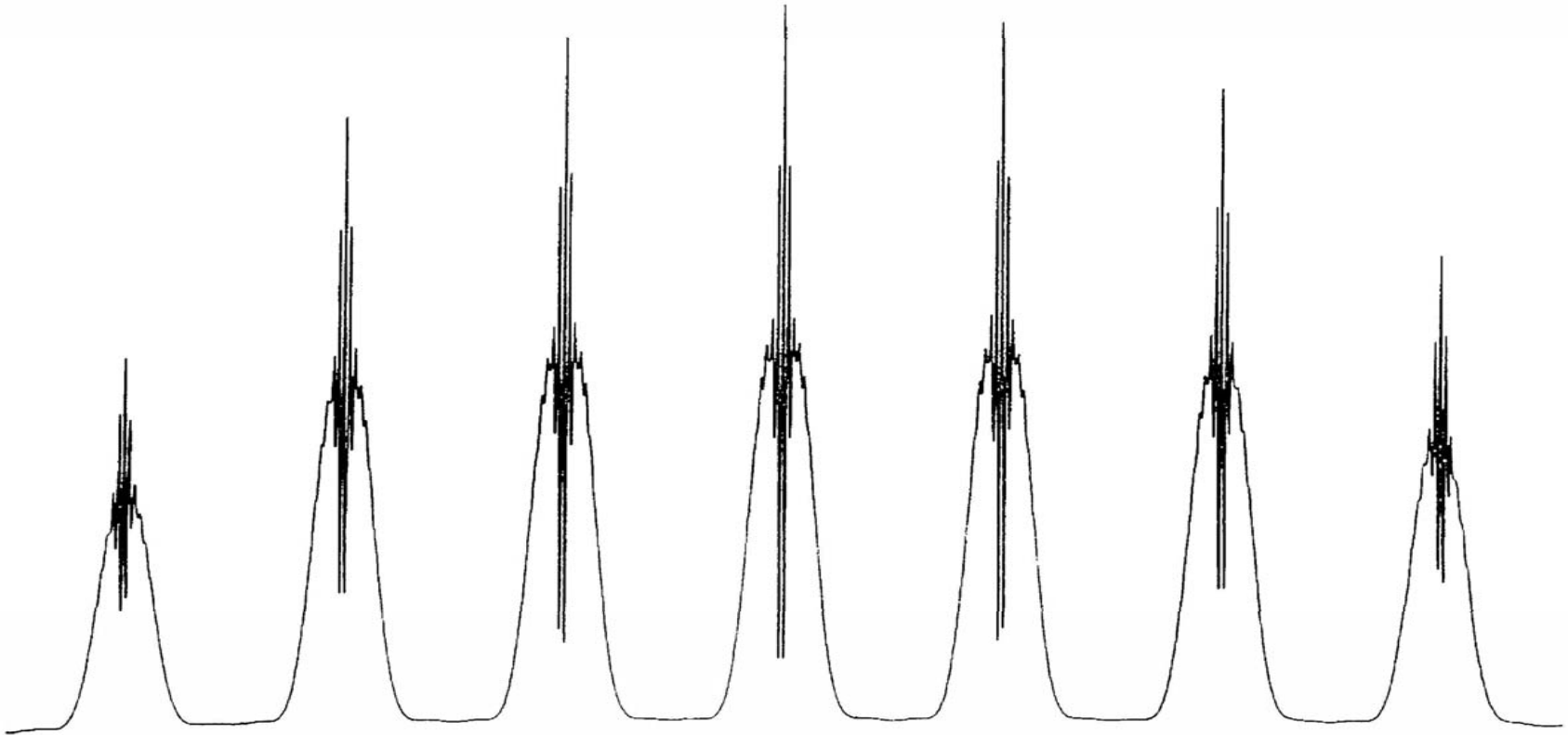

Cesium Spectrum

(high resolution)

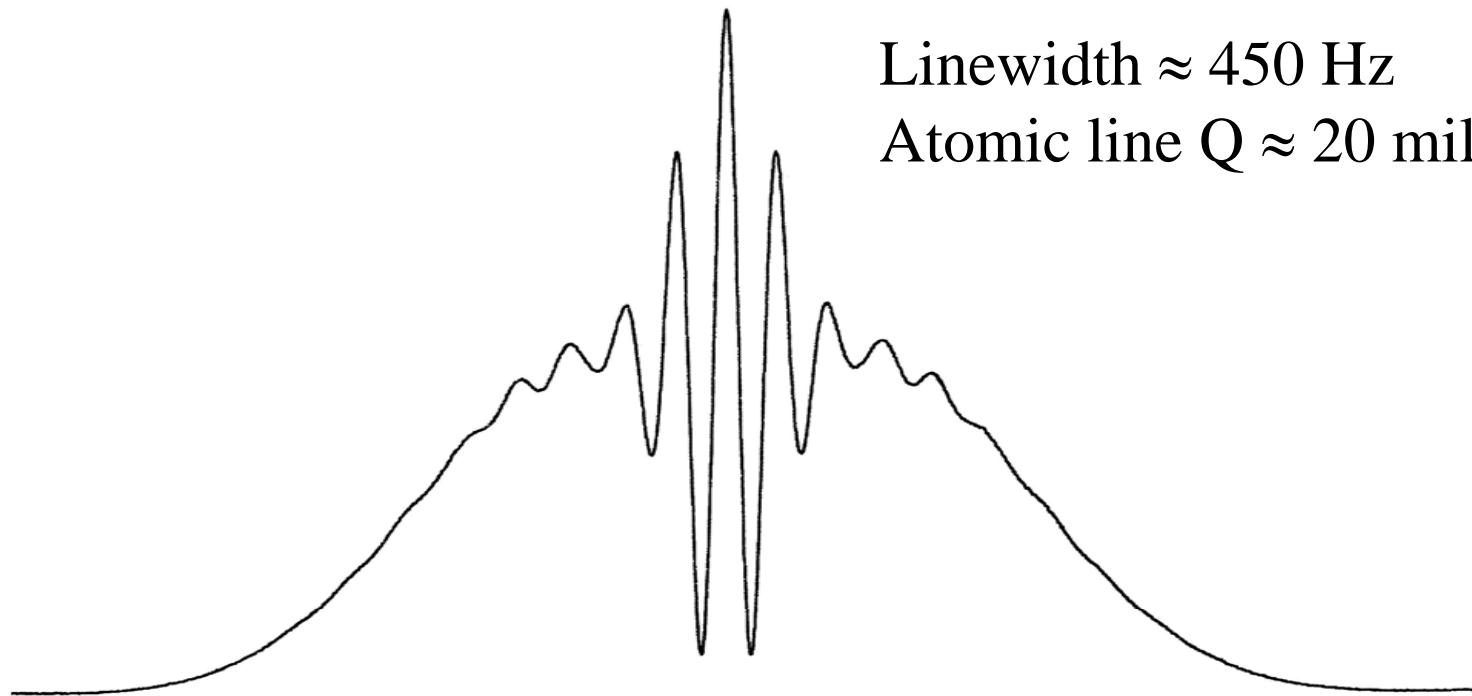

Linewidth ≈ 450 Hz

Atomic line $Q \approx 20$ million

$$\nu_0 = 9\,192\,631\,770 \text{ Hz}$$

Cesium Beam Block Diagram

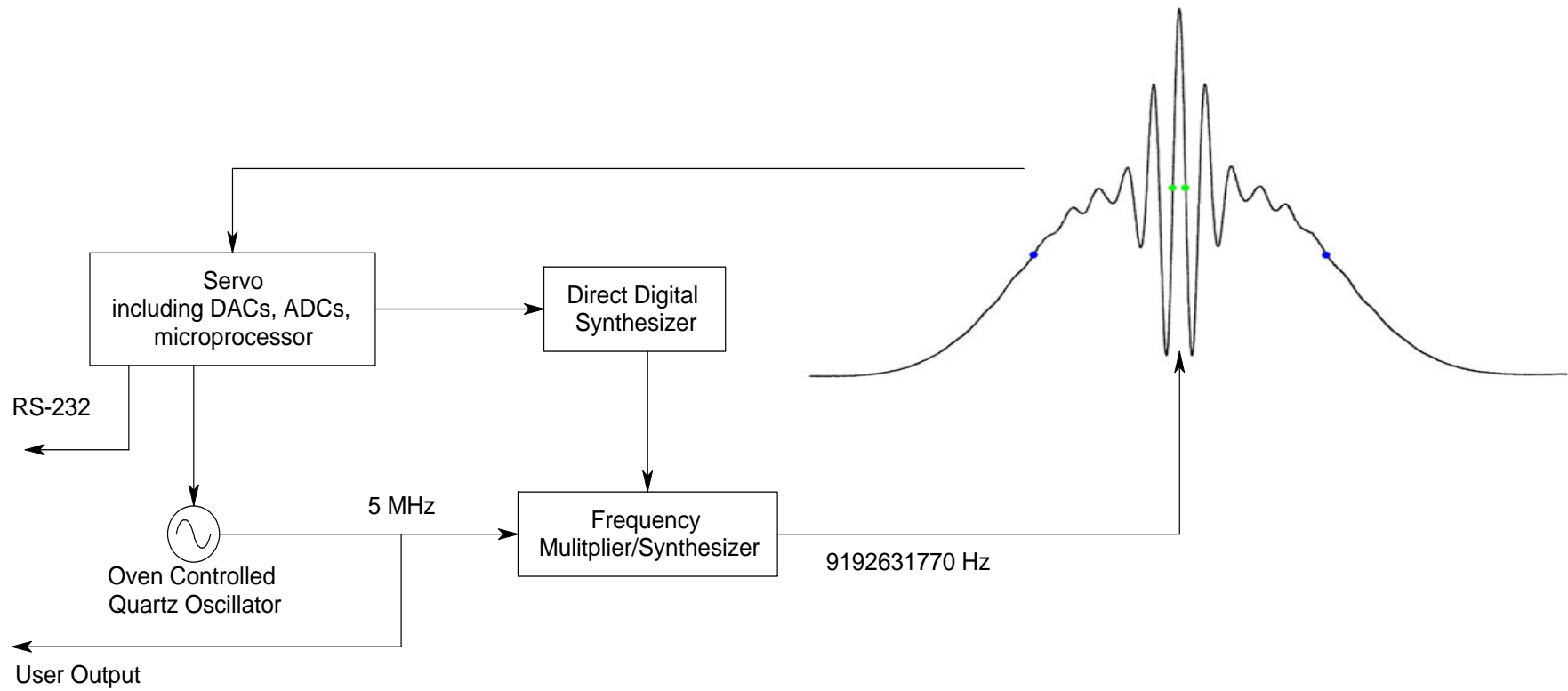

- ▶ + Cesium beam is a primary standard and does not require calibration
- ▶ + Beam has no interaction with its “confinement”
 - Most accurate and most stable atomic clock, in long term
- ▶ + No first order Doppler frequency offsets in properly designed and built apparatus
- ▶ + Beam density is low enough for minimal self-interaction
- ▶ - Relatively complex and expensive apparatus
- ▶ - Linewidth limited by time-of-flight through the apparatus
- ▶ +/- Lifetime: 6 years for high performance; 12+ years for standard performance



Symmetricom®

National Company
Atomichron
circa 1958



Symmetricom
TimeCesium
circa 2007



Symmetricom
5071A
Circa 2007

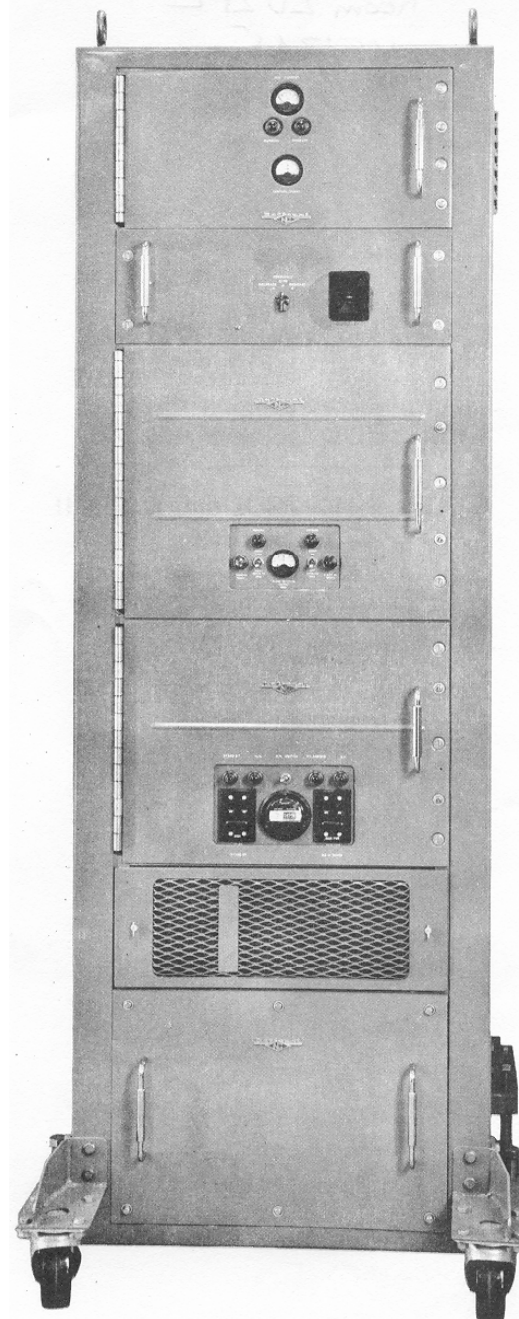

Active Hydrogen Maser Frequency Standards

Active Hydrogen Masers



- ▶ Active masers provide the best short term frequency stability for averaging times less than 1 day
- ▶ Mature technology with good operating lifetime and reliability
- ▶ Relatively large, complex and expensive
- ▶ Design of choice when the ultimate frequency stability is required

Hydrogen Maser

Hydrogen Maser Physics Package

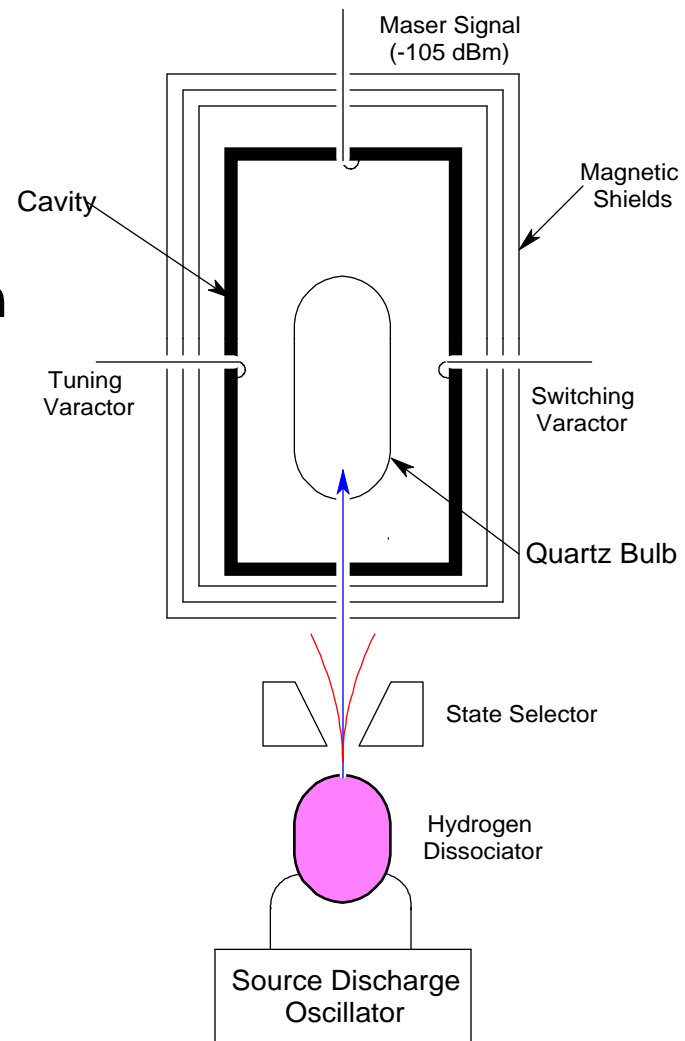

- ▶ Thermal motion of the atoms induces a second-order Doppler effect of approximately $-5e-11$.
 - ▶ Confinement (“wall shift”) of hydrogen atoms induces a frequency offset of approximately $-3e-11$.
 - ▶ Cavity pulling—dependent on cavity tuning error
 - ▶ Spin-exchange frequency shift
 - ▶ Magnetic field in the atomic environment
-
- ▶ To maintain aging of $2e-16$ /day requires that these effects be constant to better than 10 ppm/day

Active Hydrogen Maser



- Frequency Stability is +40X superior to high performance cesium
- Requires frequency calibration for most applications



MHM 2010

Passive Hydrogen Maser

- ▶ Smaller size achieved by dielectric loading of maser cavity
 - Lower cavity Q precludes maser oscillation—operates in a passive mode using traditional frequency lock loop servo
- ▶ Short term frequency stability better than cesium
- ▶ Exhibits frequency drift/aging inferior to cesium
- ▶ Small installed base; little long term experience
 - Two manufacturers in Russia

Passive Hydrogen Maser



Passive Hydrogen Maser Physics Package

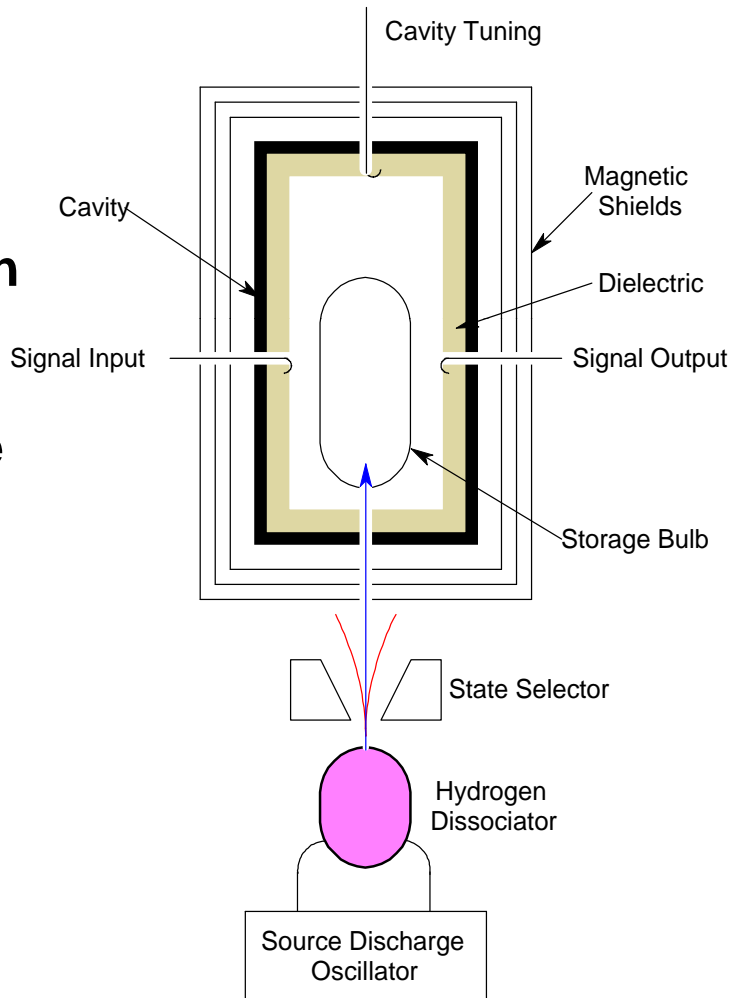

Rubidium Gas Cell Frequency Standards

- ▶ Most Widely Used Type of Atomic Clock
 - Smallest, Lightest, Lowest Power, Least Complex, Least Expensive, Longest Life, Good Performance, Stability & Reliability
- ▶ Device of Choice When Better Stability Than a Crystal Oscillator is Needed
 - Lower Aging, Lower Temperature Sensitivity, Faster Warm-up, Excellent Retrace

Gas Cell Confinement

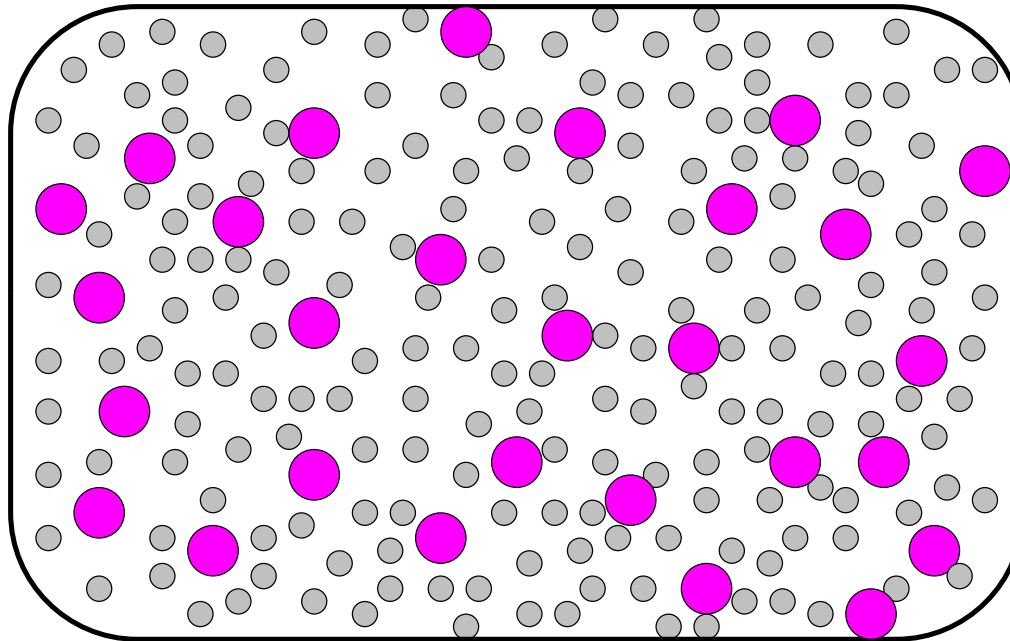

- Nitrogen
- Rubidium

- Nitrogen atoms immobilize the rubidium atoms, slowing their velocity and minimizing wall collisions
- Interaction between rubidium and buffer gas introduces large frequency offset (which must be calibrated)

Optical Pumping

--Incident pumping photons stimulate transitions into an excited optical state

--Atoms in the excited state decay to the ground states with equal probability

--Continued pumping out of one ground state effectively moves the atoms into the other state

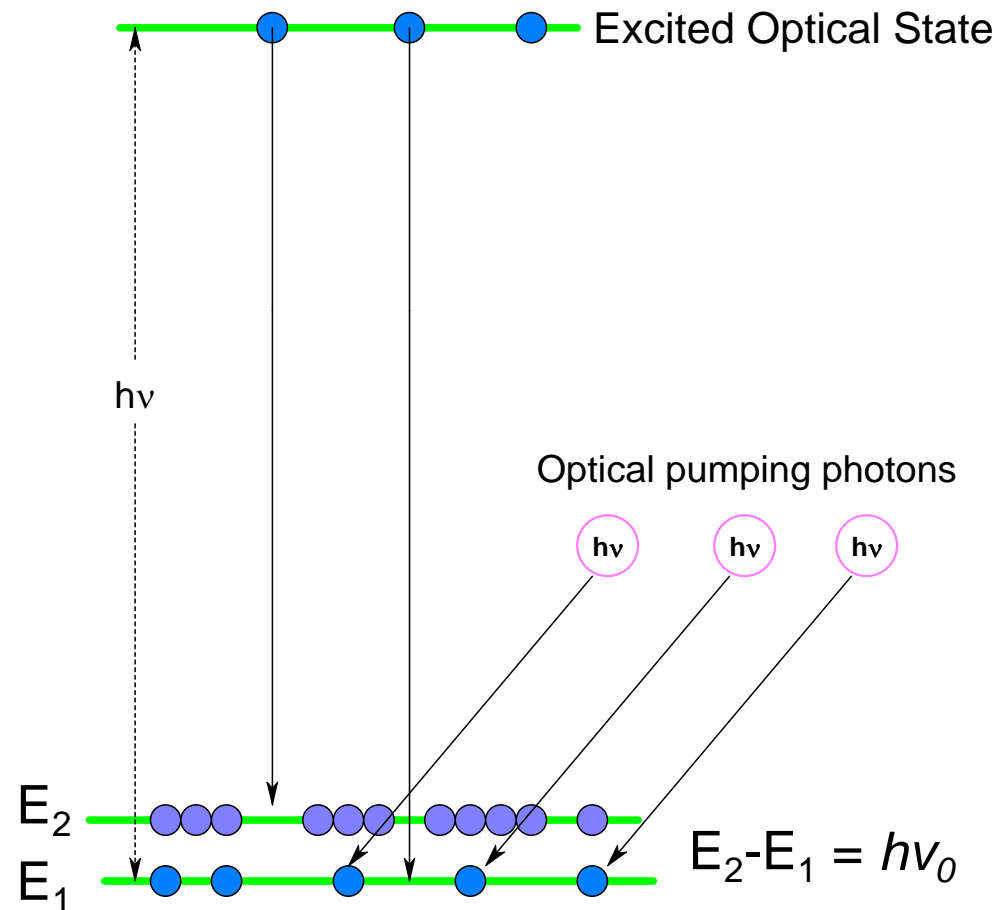

Rubidium Gas Cell

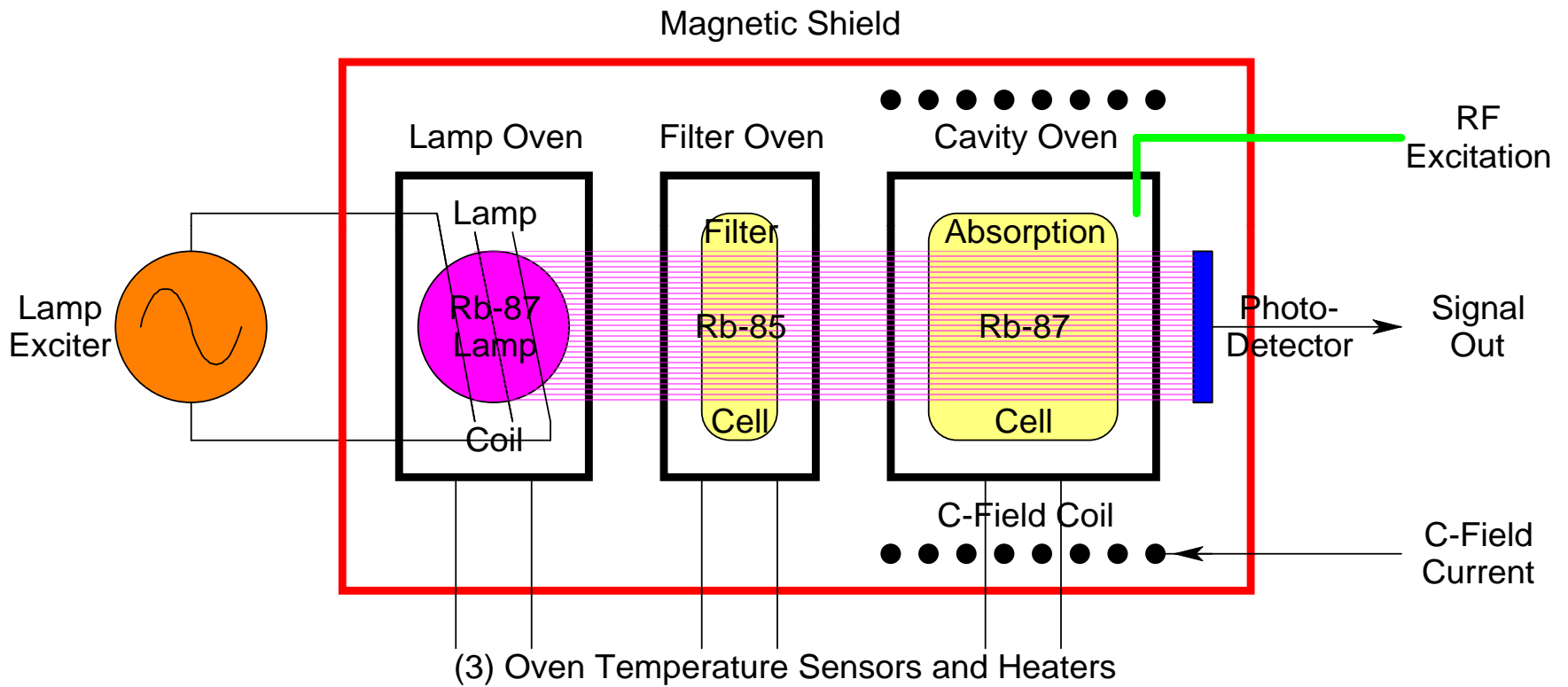

Rubidium Gas Cells



- ▶ The cells in the latest commercial RFS designs have (along with their cavities) gotten much smaller. While this comes at the expense of a broader line, lower Q and poorer short-term stability, good performance e.g. $\sigma_y(\tau) = 1e-11$ at 1 second can still be realized.



Comparison between classic 1" long (LPRO) and latest ultra-miniature (X72) integrated Rb gas cells

Gas Cell Atomic Clock Pluses and Minuses



- ▶ + Buffer gas confinement allows small size and economical construction
- ▶ + Rubidium has a fortuitous isotope overlap to allow optical pumping
- ▶ - Buffer gas introduces a large frequency shift which results in poor accuracy, is difficult to perfectly stabilize over time (aging) and environment (temperature, barometric, etc)
 - Buffer gas mixtures can reduce thermal effects, one gas with a positive temperature coefficient (N_2) and one with a negative temperature coefficient (Ar)
 - Barometric effects ($1e-10$ /atmosphere) are small and non-cumulative

Modular Rubidium Standard

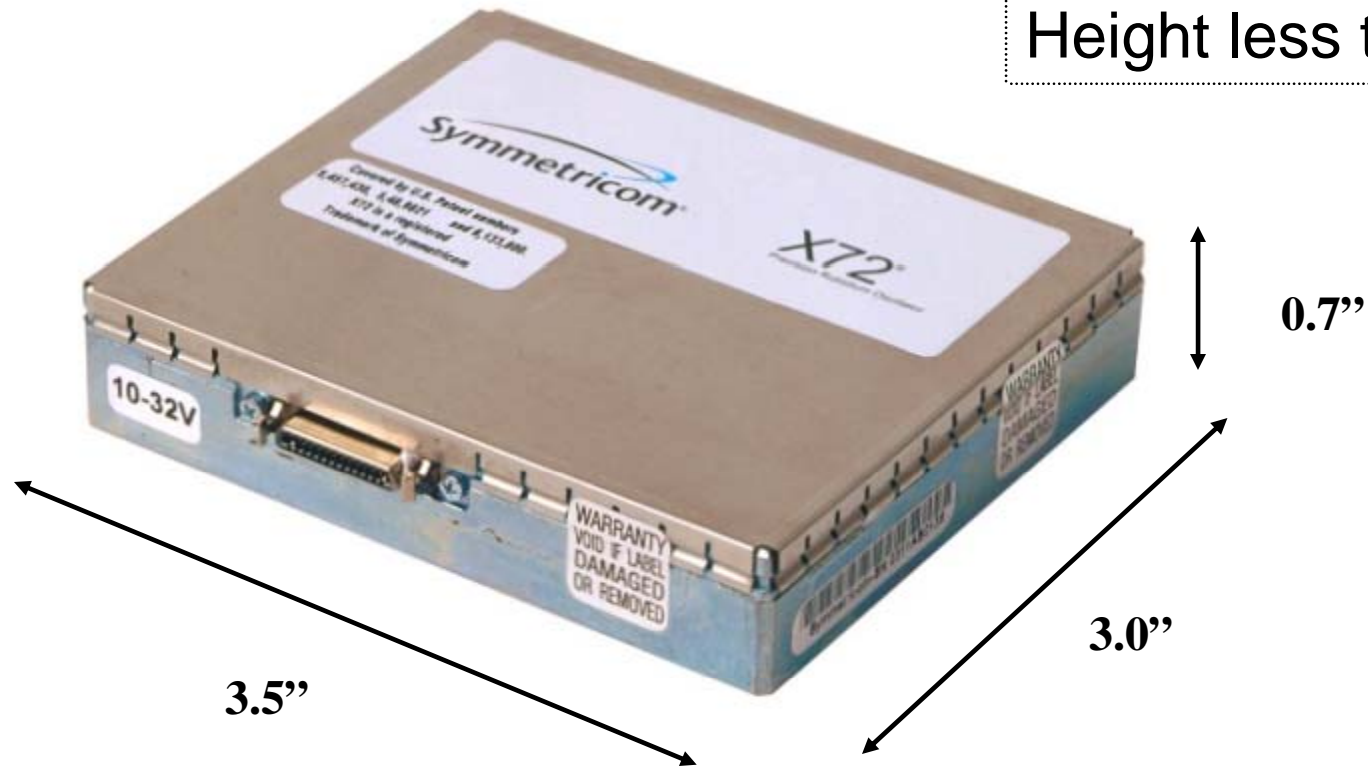

Rubidium Standard Instruments



Rack Mount Instrumentation



Defense
Customization

- ▶ Rubidium gas cell devices are secondary standards which have great utility once calibrated
 - Buffer gas offset is $\sim 1e-6$; to achieve aging of $< 5e-11$ /month requires that buffer gas properties remain constant to < 50 ppm/month (which is achieved)
- ▶ Initial calibration is a factory process following an extended period (weeks) of aging and stabilization
- ▶ Subsequent calibration may be manual or automatic (eg by servo to GPS timing signals)

Performance Comparisons

- ▶ Aging – Change in frequency over time
 - Cumulative over life or until recalibrated
- ▶ Temperature
- ▶ Short Term Stability (noise)
 - Comes from resonance Q and signal-to-noise
- ▶ Intermediate Term Stability
 - Driven by environmental sensitivities in rubidium
- ▶ Long Term Stability
 - Driven by aging in rubidium and environmental sensitivities in cesium

- ▶ Cesium beam exhibits no frequency aging behavior
- ▶ Hydrogen maser exhibits aging of $2e-15$ to $2e-16$ /day, improving with age
- ▶ Rubidium gas cell exhibits typical frequency aging of 1 to $5e-11$ /month
 - Aging effects in rubidium are not fully understood
 - Physical/chemical loss of N_2 buffer gas into the Rb film and/or glass envelope of the absorption/resonance cell?
 - Light shift (AC Stark) effects?
 - Early life rubidium aging can be much higher

- ▶ Cesium: $1\text{e-}15/^{\circ}\text{C}$ typical
 - Difficult to characterize; origin uncertain
- ▶ Maser: $<2\text{e-}15/^{\circ}\text{C}$
 - Difficult to characterize; origin uncertain
- ▶ Rubidium: 1 to $2\text{e-}12/^{\circ}\text{C}$ typical
 - Light shift effects
 - Buffer gas effects
 - RF Power effects
 - Can be ameliorated by temperature compensation

Atomic Clock Technologies



Technology	Intrinsic Accuracy	Stability (1s)	Stability (floor)	Aging (/day) initial to ultimate	Cost
Hydrogen Maser	$\sim 10^{-11}$	$\sim 10^{-13}$	$\sim 10^{-15}$	10^{-15} to 10^{-16}	$\sim 150X$
Cesium Beam	$\sim 10^{-13}$	$\sim 10^{-11}$	$\sim 10^{-14}$	nil	$\sim 20X$
Passive H Maser	$\sim 10^{-10}$	$\sim 10^{-12}$	5×10^{-15}	10^{-15}	$\sim 40X$
Rb Gas Cell	$\sim 10^{-9}$	$\sim 10^{-11}$	$\sim 10^{-13}$	10^{-11} to 10^{-13}	$\sim X$
Hi-quality Qz	10^{-6} to 10^{-8}	$\sim 10^{-12}$	$\sim 10^{-12}$	10^{-9} to 10^{-11}	$\sim 0.5X$

- ▶ Temperature Compensation Requires No Additional Hardware in Some Modern Designs.
- ▶ It Does Require More Test Effort to Measure Uncompensated TC, Calculate & Load Compensation Data, and Confirm Compensated TC.
- ▶ Dynamics Limit Amount of Improvement – Temperature Sensor Location and Response Time Are Factors.
- ▶ Compensation May Degrade Short-Term Stability Depending on Tuning Resolution and Compensation Algorithm.

Emerging and Advanced Clock Technologies

- ▶ Coherent Population Trapping Clocks
 - Uses lasers to perform the optical pumping
- ▶ Chip Scale Atomic Clocks
 - Ultra miniature size and low power requirement
- ▶ Optically pumped cesium beam
 - Use optical techniques for state selection and detection
- ▶ Fountain Clocks
 - Atoms are cooled and “tossed” upward in Earth’s gravity
 - Used for primary standards where ultimate accuracy is desired
- ▶ Optical clocks relying upon optical atomic transitions

Physics Comparison



Conventional Rb Physics

- Requires resonant microwave cavity
- RF Discharge lamp (*1 Watt*)
- 3 (or 2) cells, ovens, controllers

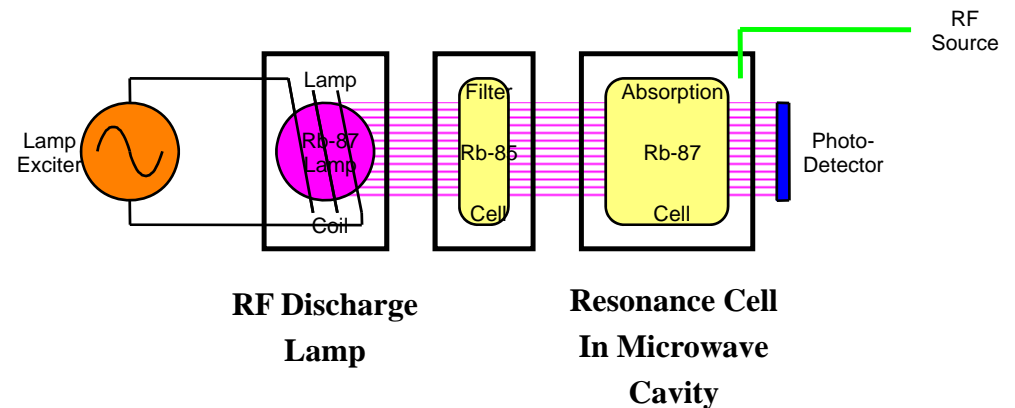

Coherent Population Trapping (CPT) Physics

- High-bandwidth Vertical-Cavity Surface Emitting Laser (*VCSEL*)
- Microwaves applied directly to VCSEL (*No cavity*)
- Potential for very small oven assembly

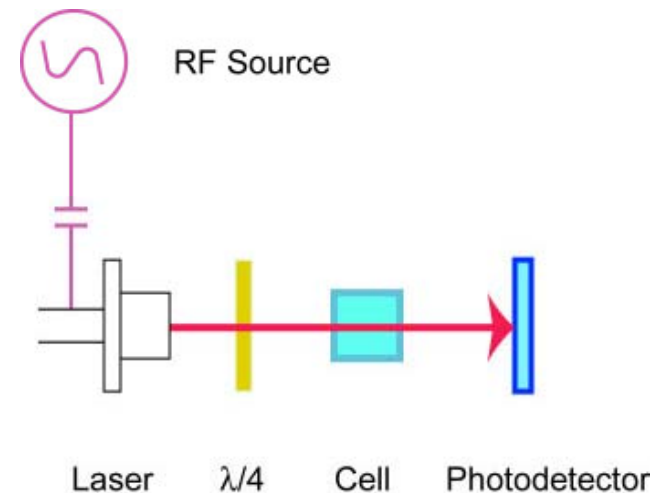

Symmetricom SA.31m



Smaller Size (1/3 X72)
51x51x18 mm
Lower Power (1/2 X72)
5 W, 25 °C
Quartz oscillator footprint



Chip Scale Atomic Clock



- ▶ Ultra small, ultra low power, modest performance
- ▶ Power: <30 mW
- ▶ Stability: <1e-11 Allan deviation at 1 hour averaging time
- ▶ Size: < 1 cm³

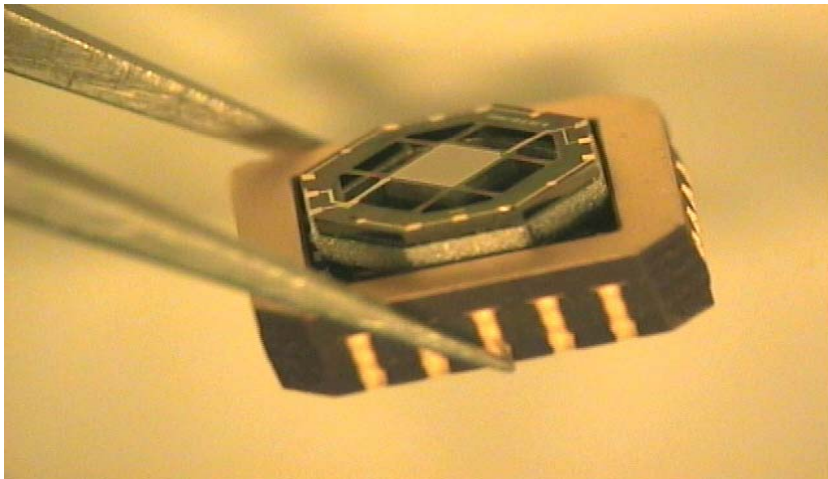

CSAC Physics Package



CSAC Prototype

Optically Pumped Cesium Beam

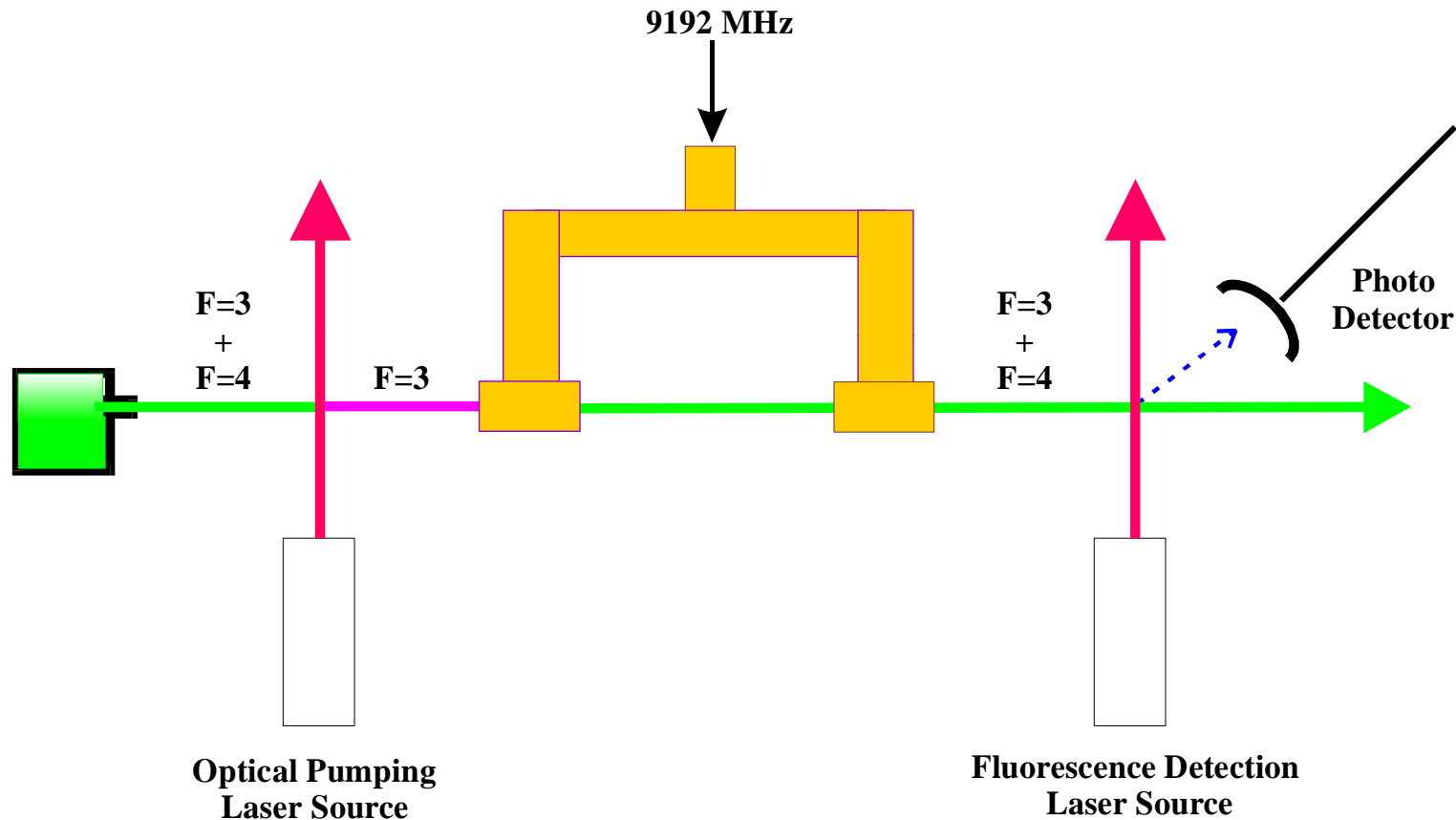

Optically Pumped CBT

- ▶ R&D Team at Symmetricom Technology Realization Center
 - Donald Emmons
 - Robert Lutwak
 - Jinquan Deng
 - Ahmed Rashed