

Time and Timing Issues within the Wireless Application Home Environment

Dr. Hugh Melvin,
Dept. of Information Technology, National
University of Ireland, Galway

(email: hugh.melvin@nuigalway.ie)

Dr. Peter Corcoran,
Dept. of Electronic Engineering, National
University of Ireland, Galway

Dr. Liam Murphy
School of Computer Science and
Informatics, University College Dublin

Performance Engineering Laboratory
www.perfenglab.com



<http://perfenglab.com>

Outline

- Background Research
- Time & Timing within IP Multimedia Applications
 - Voice & Video over IP
 - Streaming
 - Gaming
- Challenges of Wireless Ubiquity
 - VoIP / Wireless speaker scenario
 - Delivering NTP over wireless
- Conclusions



<http://perfenglab.com>

Background Research VoIP .. again

- VoIP : Adaptive Jitter Buffer Algorithms
 - Jitter buffer absorbs packet arrival jitter
 - Adaptive buffer tracks network
 - Implemented via silence period adjustment
 - QoS impact unknown
 - No Time Synch between endpoints
 - No knowledge of actual M2E delay
 - Adjustments often unnecessary in context of acceptable M2E delay

Adaptive Jitter Buffering

Adaptive Playout Strategy

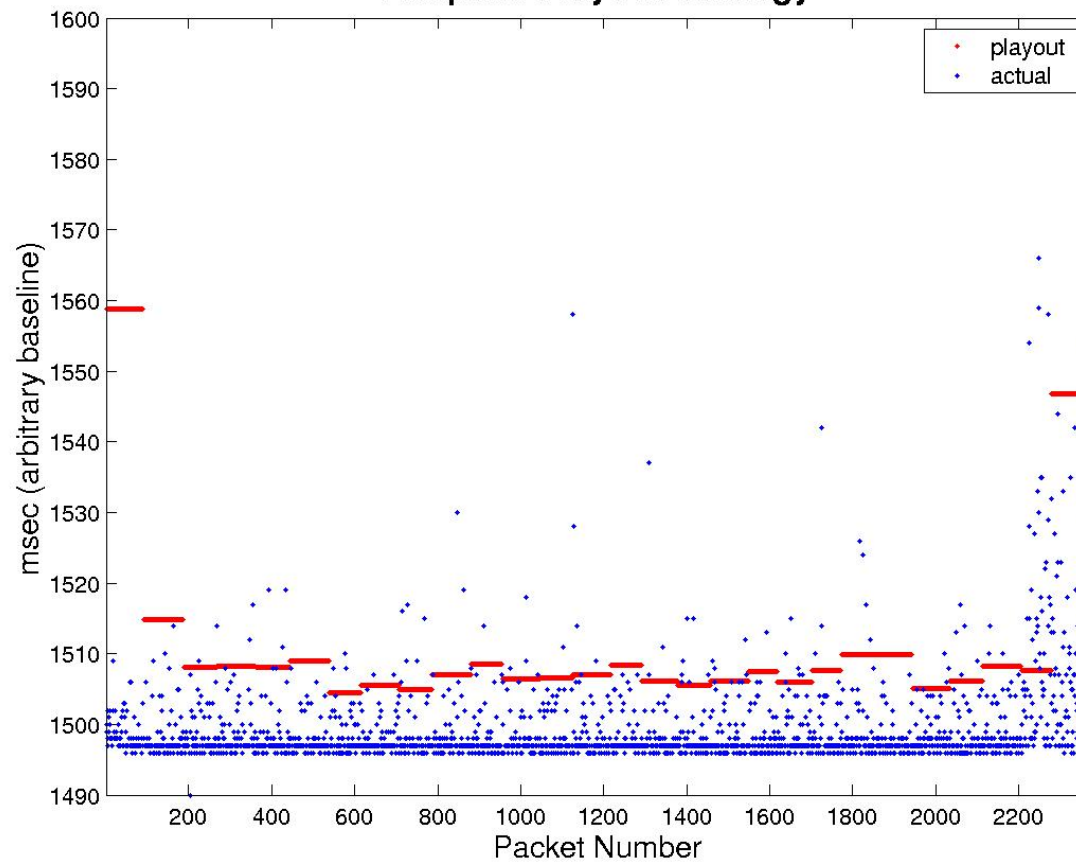



<http://perfenglab.com>

Hybrid Playout Algorithm

- Hybrid Algorithm
 - Based on synchronised time across different hosts
 - Minimise late loss at expense of increased delay
 - ITU-T E-Model
 - Net gain in user-satisfaction R-factor
 - Added (unquantified) benefit of reduced silence period distortion
 - Synchronised time provided by NTP
 - Precise delay info facilitated by RTCP SR packets

Hybrid Alg.: Synchronised Time

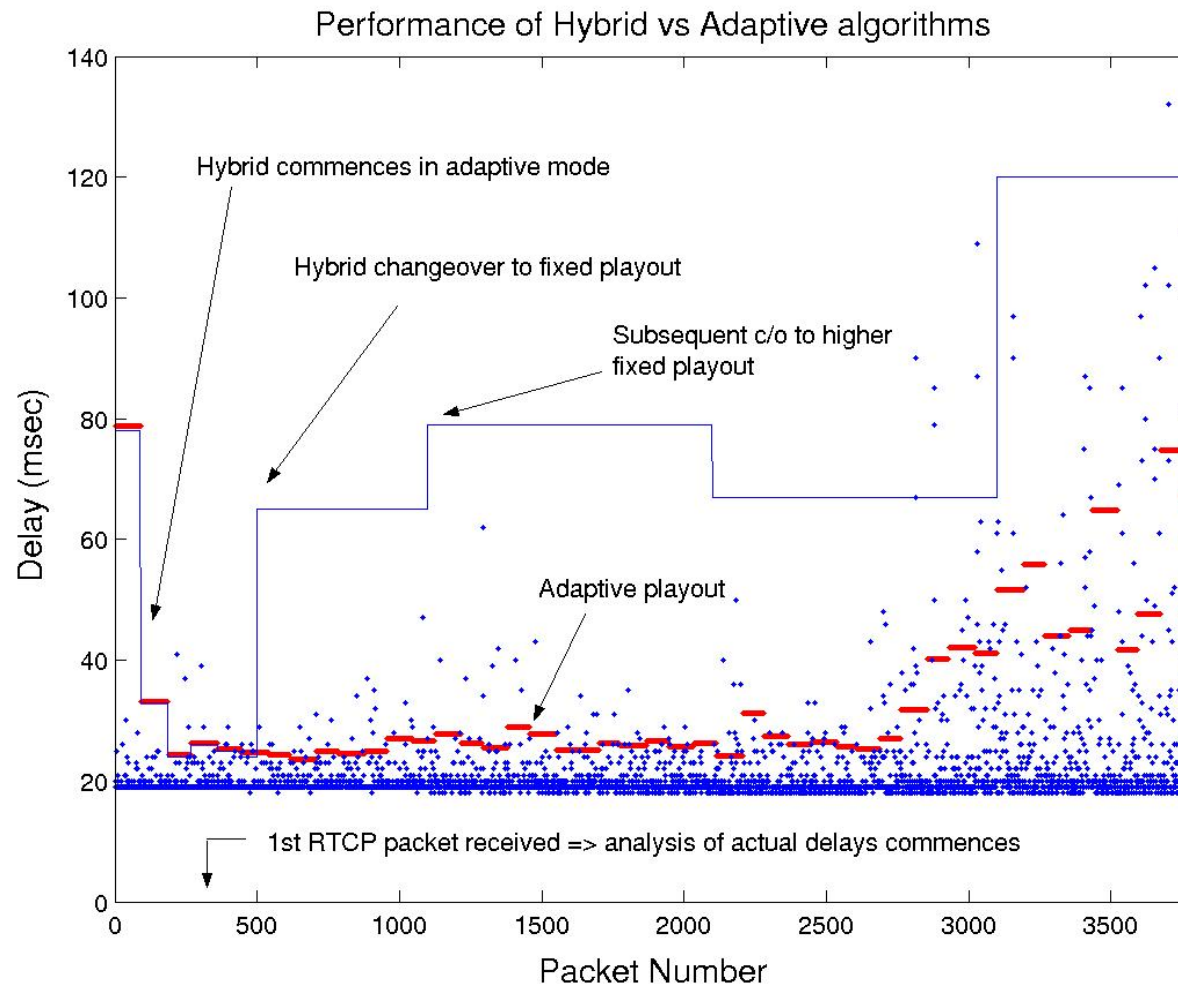



<http://perfenglab.com>

RTP & RTCP

- RTP useful for intra-stream synchronisation (reconstruction)
- RTCP SR useful for inter-stream synch for different streams eg lip-synch *from same host*
 - *Synch Time across hosts not reqd*
- *What if we want to synch different media streams from different hosts ?*
 - *Require Synchronised Time **across** hosts*

Detectability and Acceptability Thresholds for lip synch ETSI STQ

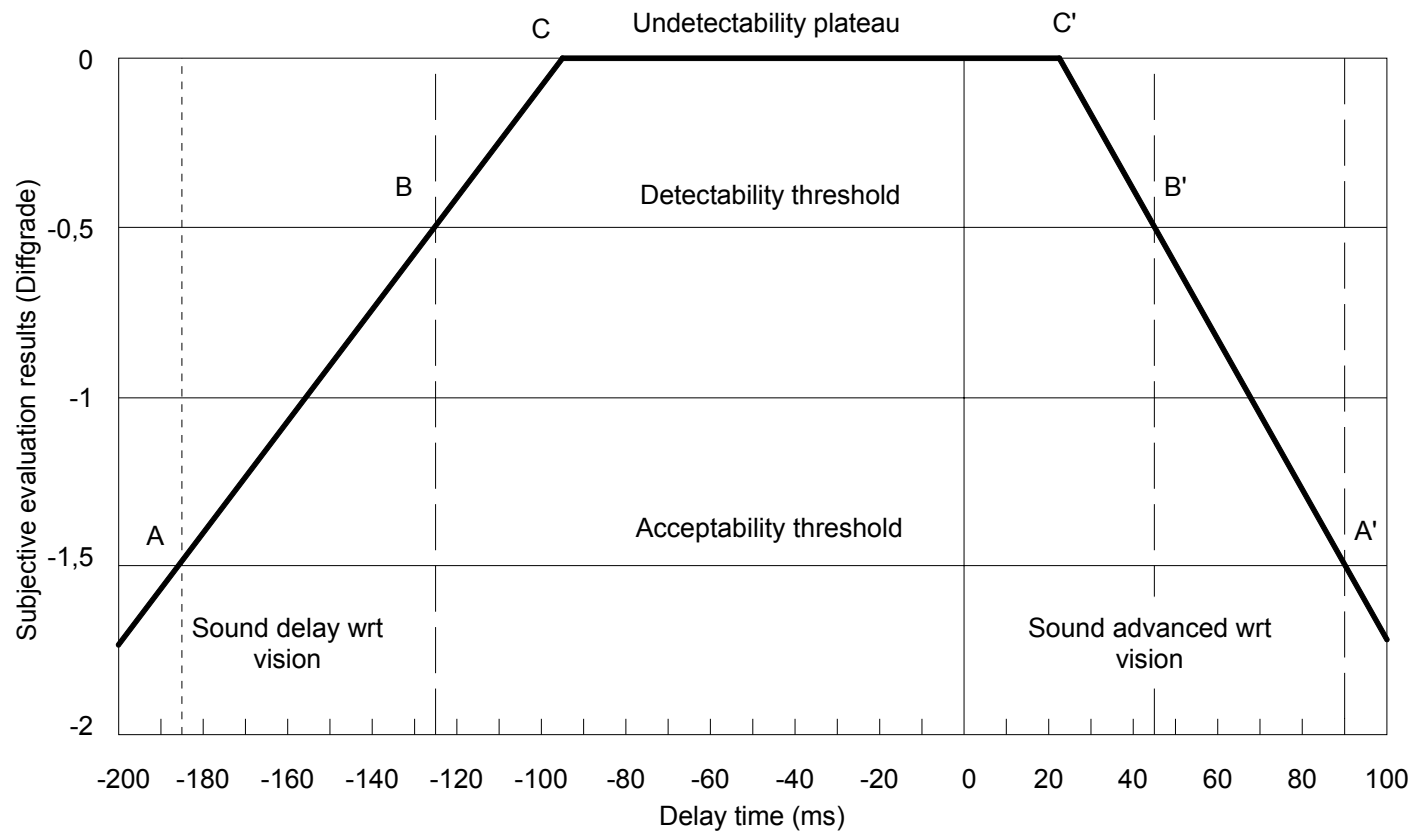

Lip Synchrony via RTCP SR

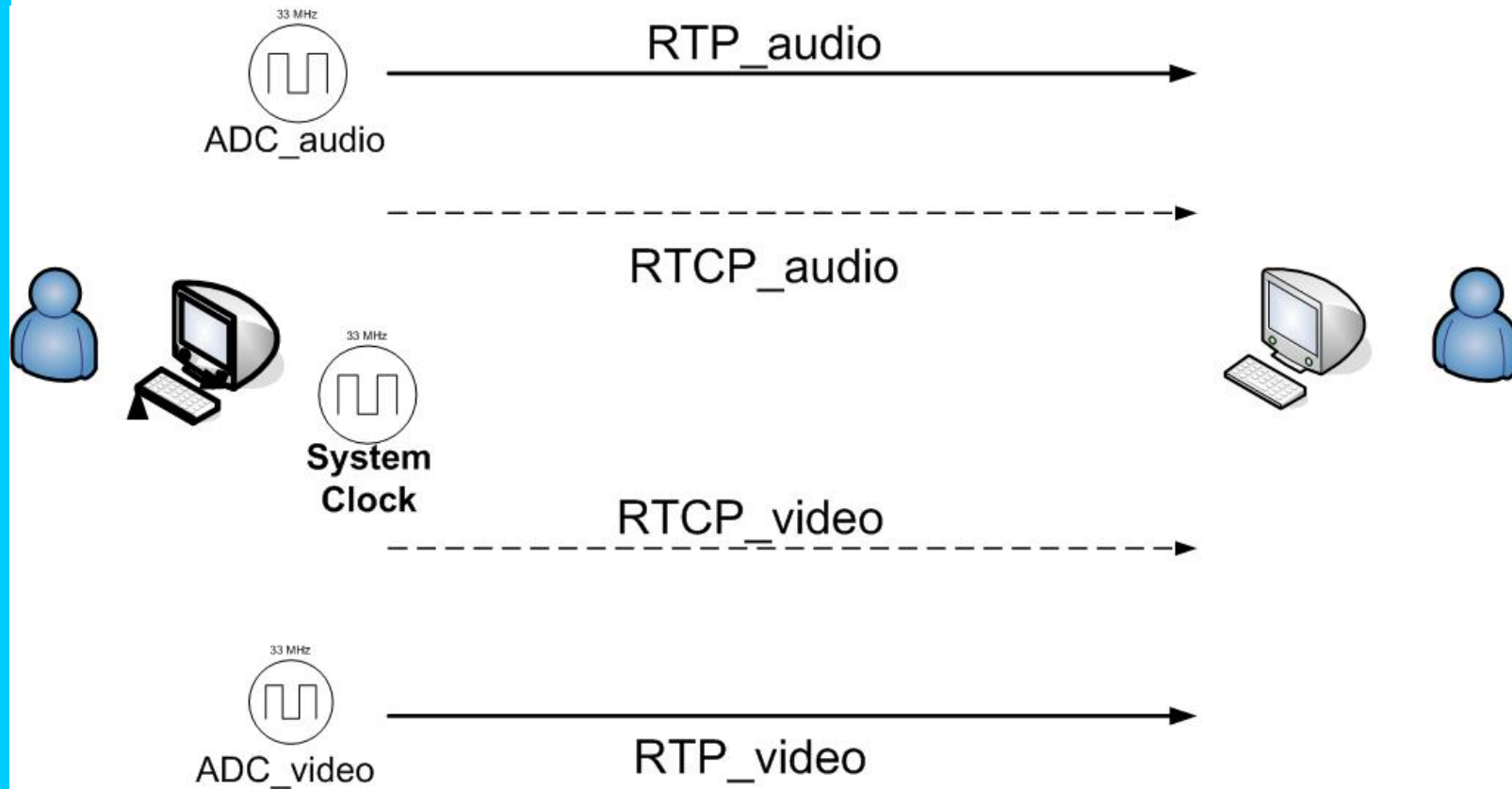



<http://perfenglab.com>

Benefits of Synchronised Time

- VoIP / Video over IP
 - Precise Delay Information
 - Improved QoS (E-Model analysis)
- Gaming
 - MMOG market growth
 - Equalisation of delays
 - *Levels the playing pitch for all participants*

Synch Time for MMOG

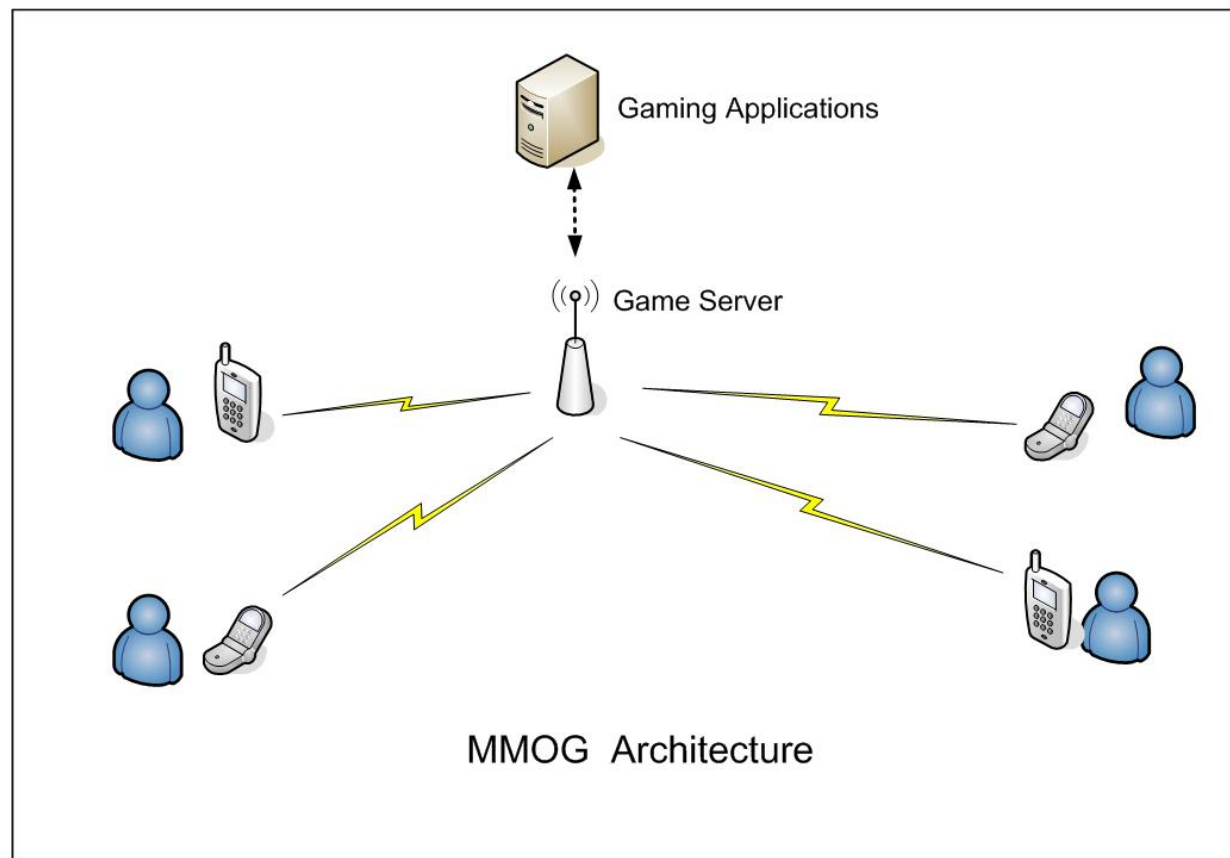



<http://perfenglab.com>

Synchronised Timing

- NTP synchronises *system* clocks
- *Media* clocks are often separate subsystem
- Multiplicity of clocks introduces complexity
- Skew in VoIP Terminals / Gateways
 - Increasing delay → QoS issue
 - Buffer overflow/underfill → Pkt loss/discontinuity → QoS issue
- Similar problems for Gaming
 - Delay & Packet Loss
- Streaming
 - Pkt loss rather than delay key issue

Timing 'Skew' for IP Multimedia

IP-IP Session

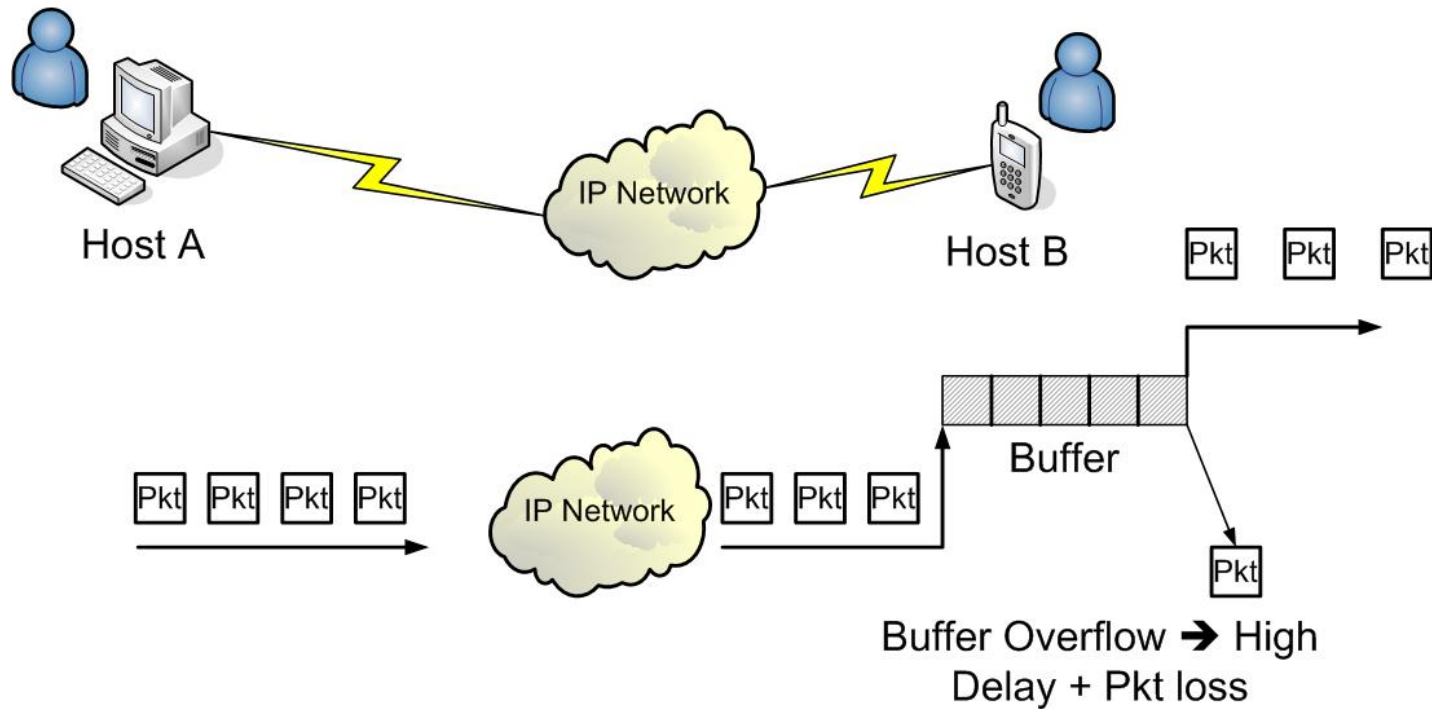



<http://perfenglab.com>

Skew Solutions in wired world

- Various skew detection and compensation mechanisms
 - Low level buffer monitoring to determine skew
- Patented NTP/RTCP approach
 - Based on Synchronised time
 - Independent benefits



<http://perfenglab.com>

Wireless Ubiquity

- Rapid growth in both Home & Office wireless LANs
 - IEEE 802.11 a/b/g/e
- Demand for similar IP Multimedia applications over wireless networks
 - Voice and Video over IP
 - Streaming
 - Gaming



<http://perfenglab.com>

Wireless Challenges

- Most wired LAN networks are Fast/Gigabit Switched Ethernet
 - Little/No contention & Overprovisioned (so far)
 - Reasonably deterministic
 - Switches can be QoS enabled (often not reqd)
 - WAN provides challenges
- Wireless (802.11) LAN
 - A return to contention based LAN networks
 - CSMA CA
 - Relatively low bandwidth
 - Significant delay & jitter at DLL
 - QoS challenges



<http://perfenglab.com>

Wireless Challenges

- Increased delay jitter due to
 - Contention level & Signal degradation/interference
- Additional problems for
 - VoIP .. buffer/delay management
 - Gaming .. buffer/delay management
 - Streaming
 - Buffer management
 - Stream Alignment for multiple parallel streams
 - Wireless Speakers

Wireless Streaming

Synchronisation of Media Streams

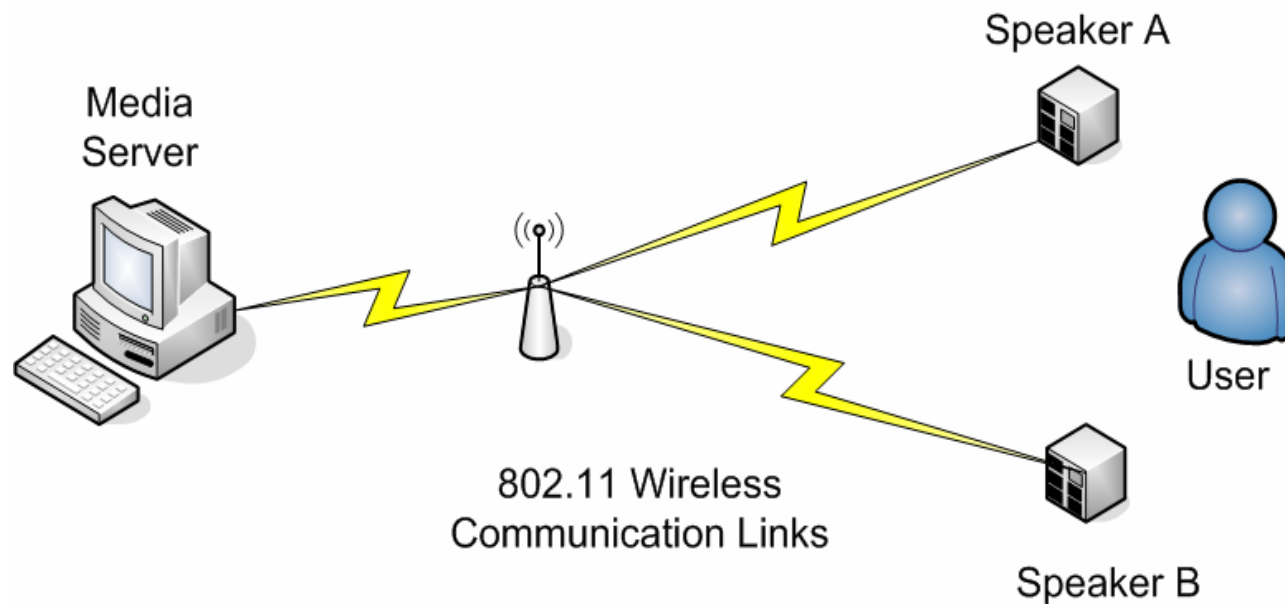



<http://perfenglab.com>

Wireless Streaming

- Playout from speakers A & B needs to be very tightly synchronised
- Impact of delay difference (Haas Effect)
 - $\Delta T < 30$ msec
 - Sensory inhibition
 - Only hear the 1st
 - Brain processes ΔT to determine sound source
 - $\Delta T > 30$ msec
 - Two distinct sounds heard .. Echo
 - Both undesirable!



<http://perfenglab.com>

Cause of ΔT

- Delays to speaker A and B may be very different due to 802.11 characteristics
- Skew between media clocks A & B will cause cumulative misalignment over time
 - 100 ppm = 60 msec over 10 minutes



<http://perfenglab.com>

Wireless Challenges

- Have outlined benefits of synchronised time to **wired** applications such as VoIP/gaming/streaming
- Benefits in **wireless** environment are even greater due to significantly greater delay jitter / non determinism
 - Wireless streaming to > 1 media sink has extra requirement for synchronisation



<http://perfenglab.com>

NTP in Wireless Environment

- Presents greater challenges
 - NTP operation is based on symmetric networks
 - Wireless networks can be very asymmetric
 - 802.11 'Reliability' will lead to NTP offset errors
 - Server & Path diversity in NTP design
 - Helps identify/eliminate servers on asymm links
 - 802.11 provides common weak link
 - What about 'new' 802.11 e
 - QoS over 802.11



<http://perfenglab.com>

Wireless QoS via 802.11e

- Default Best Effort ping
 - 13 packets transmitted, 13 packets received, 0% packet loss round-trip min/avg/max/stddev = 2.485/16.492/31.758/11.551 ms
- QoS Enabled ping
 - 12 packets transmitted, 12 received, 0% packet loss, time rtt min/avg/max/mdev = 2.458/3.705/6.478/1.119 ms
 - Cf <http://forums.star-os.com/showthread.php?t=6974>
- Much lower delay and jitter..but
- What happens when QoS channel is abused?



<http://perfenglab.com>

Conclusion

- Strong awareness of benefits of synch timing
- Less awareness of benefits of synch time
- Does the user currently care ?
 - Wired IP world :
 - QoS seen as acceptable ?
 - Other more pressing problems in network and terminals
 - Wireless IP world
 - Benefits of synch time more significant
 - Wireless speaker: very noticeable impact
 - May raise awareness of benefits?